



# 1GM10

Configuration	In-line, 4-stroke, vertical, water-cooled diesel engine	
Max. output at crankshaft*	6.6 kW@3600 rpm	[9 mhp@3600 rpm]
No. of cylinders	1 cylinder	
Displacement	0.318 L	[19.41 cu in]
Bore x stroke	75 mm x 72 mm	[2.95 in x 2.83 in]
Aspiration	Natural	
Combustion system	Indirect injection, in-line pump	
Starting system	Electric starting 12V - 1.0 kW with manual combination	
Engine management	Mechanical	
Cooling system	Direct seawater cooling by rubber impeller seawater pump	
Alternator	12V - 40A	
Lubrication system	Enclosed, forced lubricating system	
Engine lube oil specifications	API class: CC or higher (refer to operation manual for SAE grade)	
Direction of rotation at crankshaft	Counterclockwise (CCW) viewed from stern	
Dry weight without gear	71 kg	[156.5 lbs]
Engine dimensions† L x W x H	554 x 410 x 485 mm	
Emission compliance	EU: RCD 2, BSO II, EMC	US: EPA Tier 2
Flywheel housing size	SAE #6	
Controls	Mechanical	

**NOTE:**

Fuel condition: Density at 15°C = 0.84 g/cm³; 1 kW = 1.3596 mhp = 1.3410 HP  
 Technical data is according to (ISO 8665) / (ISO 3046)

\* Fuel temperature 40°C at the inlet of the fuel injection pump (ISO 8665)

†Length includes KM2P-1 marine gear (Dimensions may vary with other gears/elbow)

**DIMENSIONS**

**Rear view**

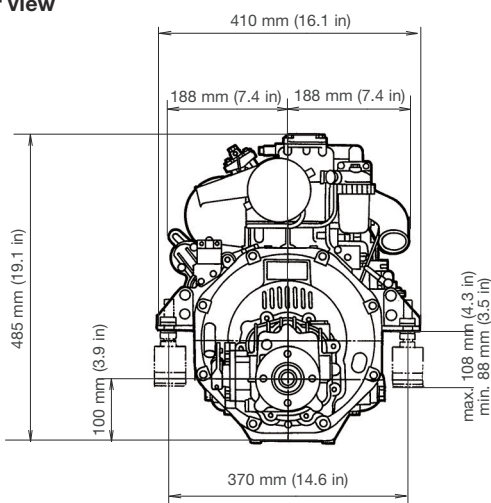

**Right side view**

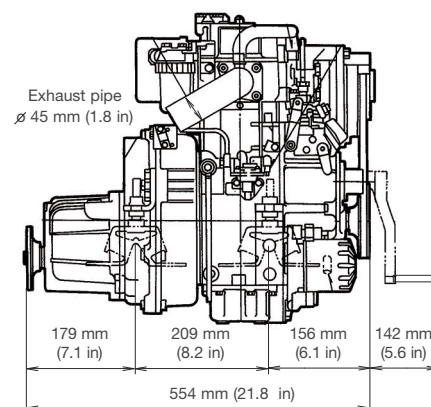

1GM10 with KM2P-1 marine gear  
 (Not to be used for engine installation)



PERFORMANCE CURVES

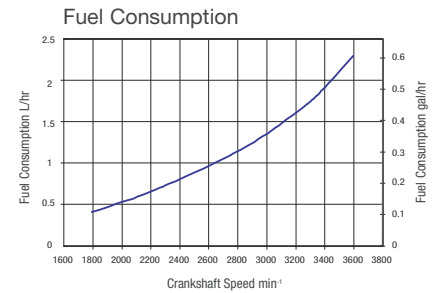
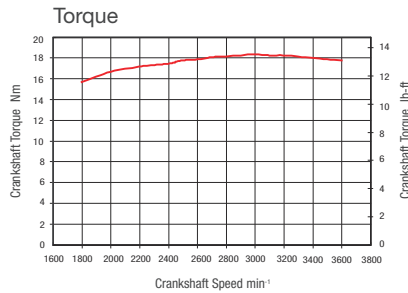
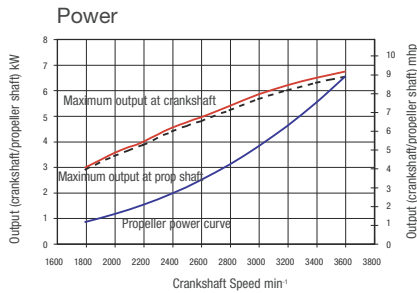

MARINE GEAR / DRIVE\*

Model	KM2P-1		Saildrive [SD25]
Clutch type	Mechanical cone clutch		Constant mesh gear with dog clutch
Dry weight	9.8 kg [22 lbs]		30 kg [66 lbs]
Reduction ratio [fwd/asn]	2.21/3.06	2.62/3.06	3.22/3.06
Direction of rotation [viewed from stern]	Clockwise		Counterclockwise
Lubrication system	Splash lubrication		Splash lubrication
Lube oil specifications	API class: CD or higher, SAE grade: #20 or #30		API class: CC or higher, SAE grade: 10W-30
Max. lube oil capacity	0.3 L		2.2 L
Dry weight - engine & gear/drive	81 kg [178 lbs]		101 kg [223 lbs]

\* Other marine gearboxes and configurations available upon request. Contact your local supplier for more information.

INSTRUMENT PANELS

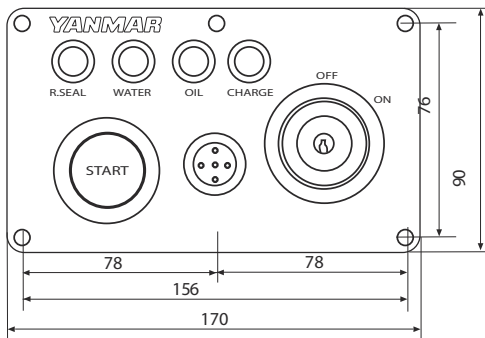

A panel

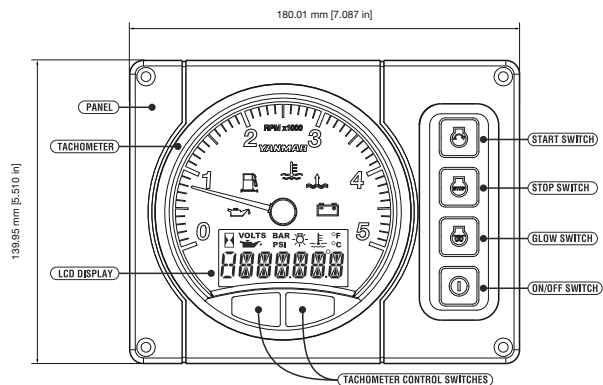

B20 panel

ACCESSORIES

**Standard engine package**

- Exhaust mixing elbow [L-type]
- Alternator 12V - 40A
- A panel
- Flexible mounts

**Optional accessories**

- B20 panel
- Extension wire harness [3m]
- TFX Sidemount control head
- Propeller cone nut kit SD25
- On-board spare parts kit

NOTE: All data subject to change without notice. Text and illustrations are not binding.