



# 4JH Series - 80 / 110

Configuration	In-line, 4-stroke, vertical, water-cooled diesel engine	
Max. output at crankshaft*	58.8 kW@3000 rpm	[80 mhp@3000 rpm]
	80.9 kW@3000 rpm	[110 mhp@3000 rpm]
No. of cylinders	4 cylinder	
Displacement	2.000 L	[1.22 cu in]
Bore x stroke	84 mm x 90 mm	[3.31 in x 3.54 in]
Aspiration	Turbocharged & intercooled	
Combustion system	Direct injection, Bosch common rail system	
Starting system	Electric starting 12V - 1.4 kW	
Engine management	Electronic	
Cooling system	Fresh water cooling by centrifugal fresh water pump	
	Seawater cooling by rubber impeller seawater pump	
Alternator	12V - 125A	
Lubrication system	Enclosed, forced lubricating system	
Engine lube oil specifications	API class: CD or higher, SAE grade: 10W-30 or 15W-40	
Direction of rotation at crankshaft	Counterclockwise (CCW) viewed from stern	
Dry weight without gear	229 kg	[505 lbs]
Engine dimensions† L x W x H	909 x 613 x 675 mm	
Emission compliance	EU: RCD 2, BSO II, EMC	US: EPA Tier 3, EPA-C
Flywheel housing size	SAE #4	
Controls	Mechanical (optional - VC20 system)	

NOTE: Fuel condition: Density at 15°C = 0.84 g/cm<sup>3</sup>: 1 kW = 1.3596 mhp = 1.3410 HP

Technical data is according to (ISO 8665) / (ISO 3046)

\* Fuel temperature 40°C at the inlet of the fuel injection pump [ISO 8665: 2006]

†Length includes KM4A2 marine gear (Dimensions may vary with other gears, drives or elbow)

## DIMENSIONS

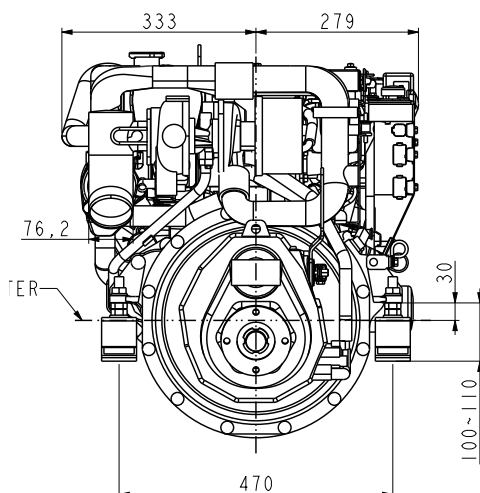
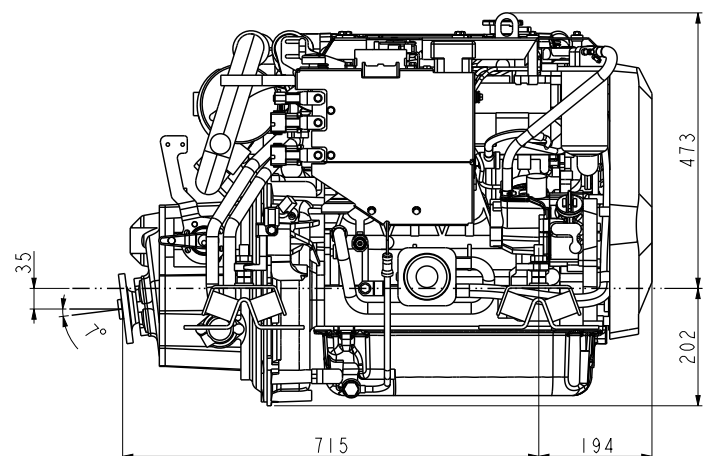
**Rear view****Right side view**

4JH80/110 with KM4A2 marine gear  
(Not to be used for engine installation)



PERFORMANCE CURVES

**4JH80 Torque curve**

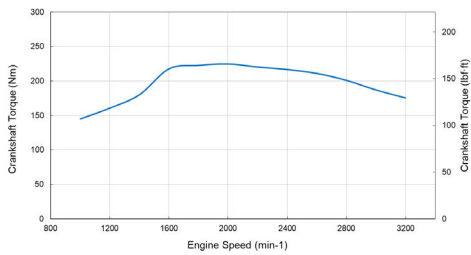

**4JH80 Output Power curve**

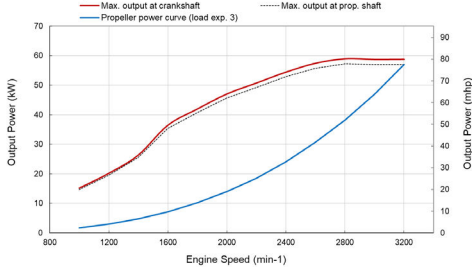

**4JH80 Fuel consumption (proload exp 3.0)**

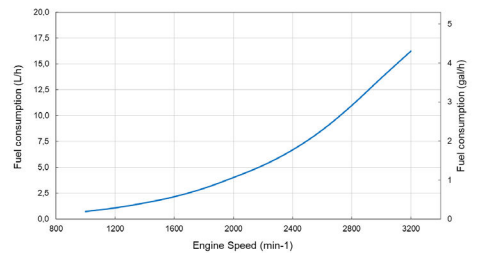

**4JH110 Torque curve**

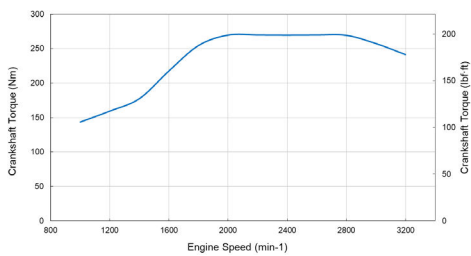

**4JH110 Output Power curve**

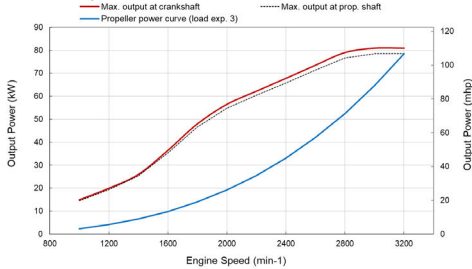

**4JH110 Fuel consumption (proload exp 3.0)**

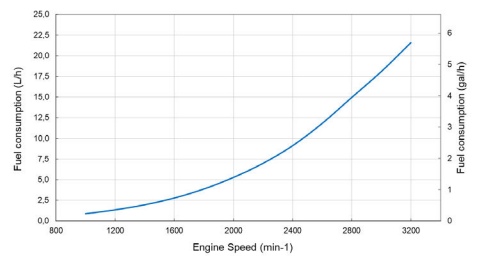

MARINE GEAR / DRIVE\*

Model	KMH4A [down angle: 8°]	KM4A2 [down angle: 7°]	ZF25A [down angle: 8°]	ZF30M [paralle]	Saildrive [SD60]**
Clutch type	Hydraulic multi disc	Mechanical cone clutch	Hydraulic multi disc	Mechanical multi-disc	Mechanical multi-disc
Dry weight	30 kg [66 lbs]	28.5 kg [63 lbs]	33 kg [73 lbs]	28 kg [62 lbs]	44 kg [97 lbs]
Reduction ratio [fwd/asn]	2.04/2.04 2.45/2.45	1.47/1.47 2.14/2.14 2.63/2.63	1.93/1.93 2.80/2.80	2.15/2.64 2.70/2.64	2.23/2.23 2.49/2.49
Direction of rotation [viewed from stern]	Clockwise & counterclockwise		Clockwise & counter-clockwise	Clockwise	Clockwise & counter-clockwise
Lubrication system	Forced lubrication	Splash lubrication	Forced lubrication	Splash lubrication	Splash lubrication
Lube oil specifications	API class: CD or higher, SAE grade: #20 or #30		ATF	ATF	API class: CD or higher, SAE grade: 15W-40
Max. lube oil capacity	2.0 L	2.0 L	1.8 L	1.1 L	2.8 L
Dry weight - engine & gear	259 kg [571 lbs]	257.5 kg [568 lbs]	262 kg [578 lbs]	257 kg [567 lbs]	273 kg [602 lbs]

\* Other marine gearboxes and configurations available upon request. Contact your local supplier for more information.

\*\* Not for 4JH110

ACCESSORIES

**Standard engine package**

- Exhaust mixing elbow [L-type]
- Alternator 12V - 125A
- Seawater pump rear mounted
- B25 panel
- Flexible mounts
- Mechanical throttle sensor
- Fuel pre-filter with water separator
- Fresh water expansion tank
- Belt safety cover

**Optional**

- High-riser mixing elbow [instead of L-elbow]
- Secondary alternator 12V - 125A or 24V - 60A
- Seawater pump front mounted
- C35 panel
- Extension harness [3m, 5m, 10m]
- Second station
- Sidemount control head
- VC20 Vessel Control System

- NMEA2000 Engine monitoring system
- Semi 2-pole
- SOLAS including Certificate [factory fit only]
- Opposite dipstick
- Hot water kit with cocks
- Extension saildrive leg [75 mm]
- Propeller cone nut kit SD60
- On-board spare parts kit

NOTE: All data subject to change without notice. Text and illustrations are not binding.