



4LV Series - 150Z / 170Z / 195Z

Configuration	In-line, 4-stroke, vertical, water-cooled diesel engine	
Max. output at crankshaft*	110 kW@3500 rpm	[150 mhp@3500 rpm]
	125 kW@3500 rpm	[170 mhp@3500 rpm]
	143 kW@3500 rpm	[195 mhp@3500 rpm]
No. of cylinders	4 cylinder	
Displacement	2.755 L	[168 cu in]
Bore x stroke	92 mm x 103.6 mm	[3.6 in x 4 in]
Aspiration	Turbocharged & intercooled	
Combustion system	Direct injection, Denso common rail system	
Starting system	Electric starting 12V – 2 kW	
Engine management	Electronic	
Cooling system	Fresh water cooling by centrifugal fresh water pump	
	Seawater cooling by rubber impeller seawater pump	
Alternator	Denso 12V - 130A	
Lubrication system	Enclosed, forced lubricating system	
Engine lube oil specifications	API class: CD or higher, SAE grade: 15W-40	
Direction of rotation at crankshaft	Counterclockwise (CCW) viewed from stern	
Dry weight without gear	334 kg	[736 lbs]
Engine dimensions† L x W x H	1151 x 755 x 772 mm	
Emission compliance	EU: RCD 2, BSO II, IMO,^ EMC	US: EPA Tier 3, EPA-C
Flywheel housing size	n/a	
Controls	Mechanical (optional - VC20 system)	

NOTE: Fuel condition: Density at 15°C = 0.84 g/cm³: 1 kW = 1.3596 mhp = 1.3410 HP

Technical data is according to ISO 8665: 2006

* Fuel temperature 40°C at the inlet of the fuel injection pump [ISO 8665: 2006]

†Length includes KMH50A marine gear (Dimensions may vary with other gears/elbow)

^4LV195 only

DIMENSIONS

Rear view

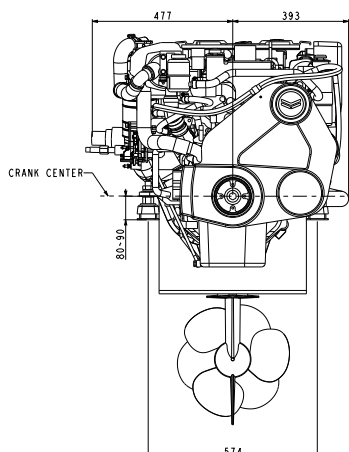

Right side view

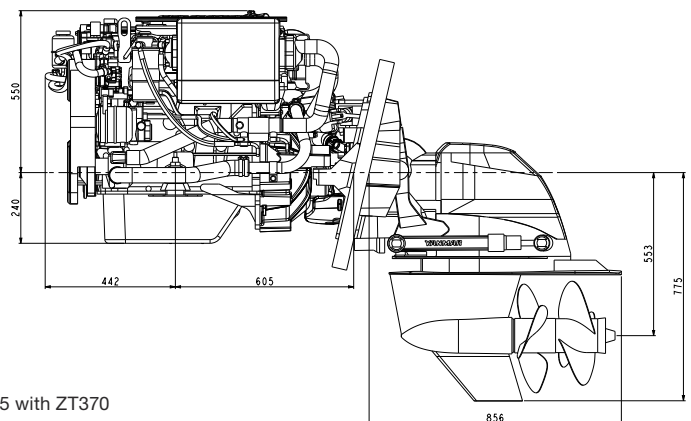

4LV150/170/195 with ZT370
(Not to be used for engine installation)



PERFORMANCE CURVES

4LV150 Torque curve

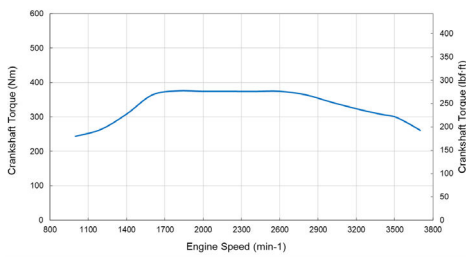

4LV150 Output Power curve

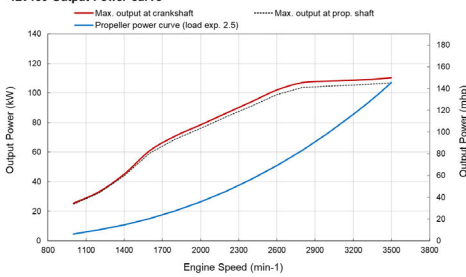

4LV150 Fuel consumption (load exp. 2.5)

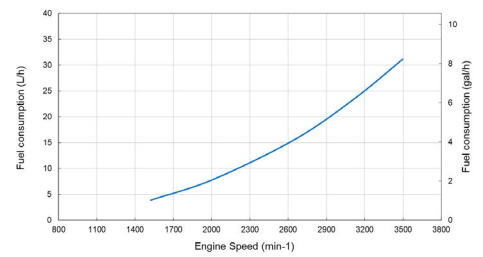

4LV170 Torque curve

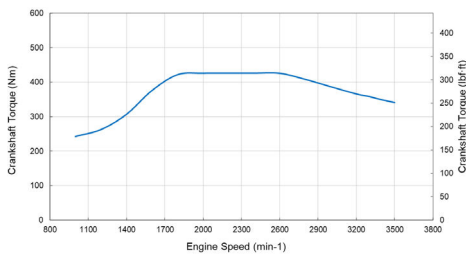

4LV170 Output Power curve

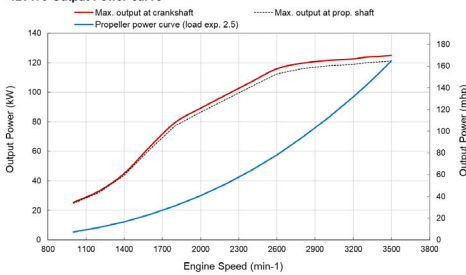

4LV170 Fuel consumption (load exp. 2.5)

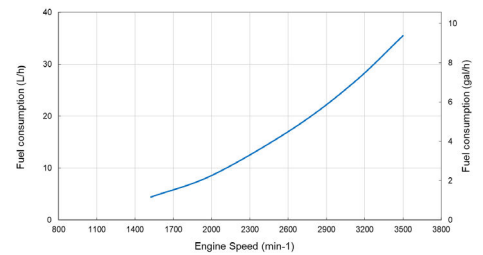

4LV195 Torque curve

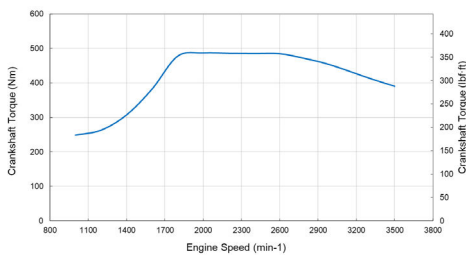

4LV195 Output Power curve

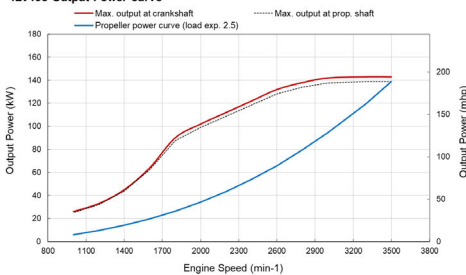

4LV195 Fuel consumption (load exp. 2.5)

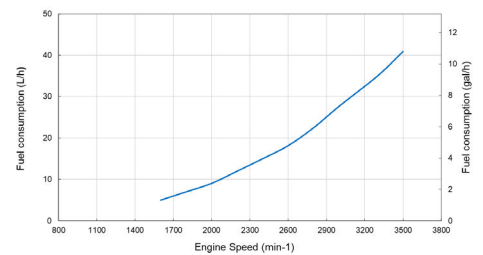

MARINE GEAR*

Model	YANMAR ZT370		
Clutch type	Hydraulic multi-disc		
Shift control	Mechanical / Electric [electro magnetic]		
Dry weight**	100 kg [220 lbs]		
Reduction ratio [fwd/rev]	1.65/1.65	1.78/1.78	1.97/1.97
Direction of rotation viewed from the stern	Clockwise [rear prop] & Counterclockwise [front prop]		
Lubrication system	Oil bath		
Lube oil specifications	Quicksilver High Performance Gear Lube		
Max. lube oil capacity	2.95 L		
Dry weight engine with sterndrive	434 kg [957 lbs]		
Trim range	-6° to +10°		
Trailer limit	51°		

* Other marine gearboxes and configurations available upon request. Contact your local supplier for more information

**Dry weight includes propellers, cooler and brackets

ACCESSORIES

Standard engine package

- Through drive exhaust
- Alternator 12V - 130A
- VC20 Vessel Control System
- Power steering
- Flexible mounts
- Fresh water expansion tank

Optional accessories

- Through hull exhaust
- Secondary alternator 12V - 130A or 24V - 110A including smart regulator
- Extension harness [3m, 5m, 10m, 20m]
- Second station
- JC10 Sterndrive Joystick
- NMEA2000 Engine monitoring system
- Internal tie-bar

- Semi 2-pole
- SOLAS including Certificate [factory fit only]
- Hot water connection
- Water separator
- Man Over Board Switch [single]
- On-board spare parts kit

NOTE: All data subject to change without notice. Text and illustrations are not binding.