

**YANMAR**

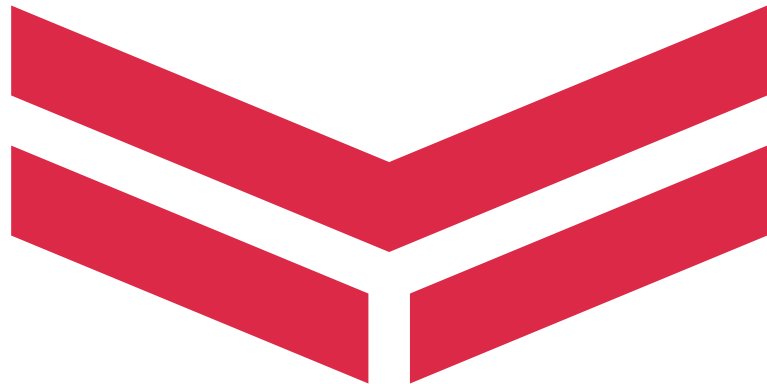

# **MARINE DIESEL ENGINE HIGH SPEED PRODUCTS GUIDE**



**YANMAR POWER TECHNOLOGY CO.,LTD.**  
**Large Power Products Business**

1-1-1, Nagasu-Higashidori, Amagasaki, Hyogo, Japan  
TEL: +81-6-6489-8069 FAX: +81-6-6489-1082

[yanmar.com/global/](http://yanmar.com/global/)



001M0-G00620 2004®

**MARINE PROPULSION**

POWER RANGE [ 8.8~1340kW ]

**MARINE AUXILIARY**

GENERATOR CAPACITY [ 20~450kWe ]

# Limitless Blue Skies and Oceans

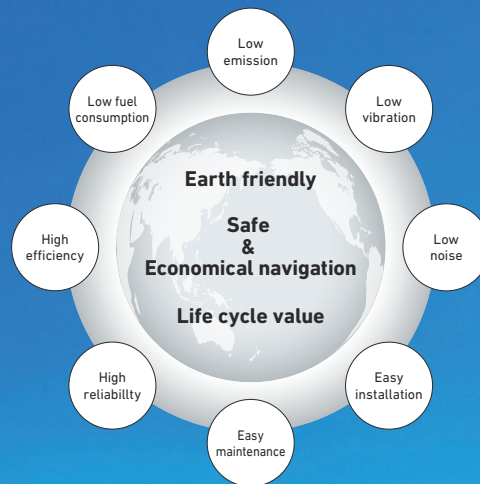

## CONTENTS

04P Environmental performance

06P Tsukaguchi factory

08P Marine propulsion diesel engine

56P Marine auxiliary diesel engine

# Clean and Reliable Technology

IMO Tier III\* requires ships built from 2016 onwards in designated emission control areas (ECAs) to have an 80% Nox reduction from Tier I levels. By 2020, sulfur content of less than 0.5% will be required for all ships as well. Time and time again, YANMAR technology has proven itself to be reliable in a wide range of commercial marine engines. In addition to this, to stay a head of the game we are continually making new technology that meets tightening emissions regulations. In addition to providing our customers with the products they need, we also improve "Life Cycle Value" of our products. With a focus on harmony with nature, YANMAR delivers optimized solutions that support longer ship life.

## IMO NOx Regulation

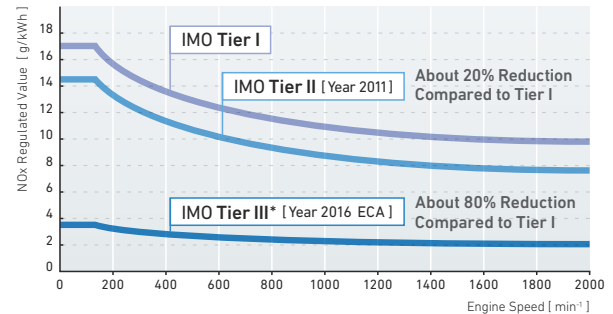

## IMO SOx Regulation

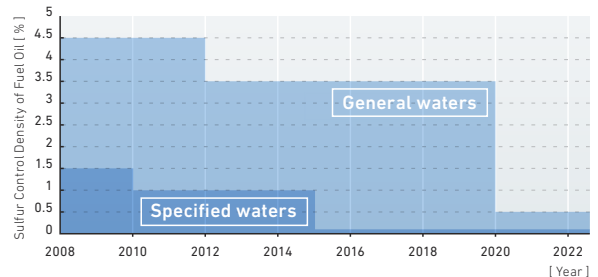

\* Tier III is applied in general waters

**ECA** = Emission Control Area

**IMO** = International Maritime Organization

**NOx** = Nitrogen Oxides

**SOx** = Sulfur Oxides

Global Hub Factory  
for Marine Diesel Engines

## Power Solution Business



Assembly Process [ Cell ]



Tsukaguchi Plant

The YANMAR Power Solution Business specializes in developing and producing small and medium-sized diesel engines mainly at the Tsukaguchi Plant. From processing of components for marine propulsion engines, marine auxiliary engines, land and industrial engines to assembly, rigging, and test runs, the Tsukaguchi Plant uses a consistent quality control system to produce a wide range of diesel engines. We deliver highly reliable products that thoroughly apply the technologies and expertise that we have fine-tuned over the years to markets in Japan and all over the world.

Certified by the seven major  
classification societies.

The Tsukaguchi Plant has been certified by world's six most authoritative shipping classification societies, LRS(Lloy'ds Register of Shipping), ABS(American Bureau of Shipping), NK(Nippon Kaiji Kyokai), BV(Bureau Veritas), RINA(Registro Italiano Navale) and KR(Korean Register of Shipping). CCS(China Classification Society).



Certifications of 7 major shipping  
classification societies

**LRS** [Lloy'ds Register of Shipping]  
**ABS** [American Bureau of Shipping]  
**NK** [Nippon Kaiji Kyokai]  
**BV** [Bureau Veritas]  
**RINA** [Registro Italiano Navale]  
**KR** [Korean Register of Shipping]  
**CCS** [China Classification Society]

The Certifications of shipping classification societies vary with the model of engine.  
For more information, please contact us.

# MARINE PROPULSION

DIESEL ENGINE  
LINE-UP

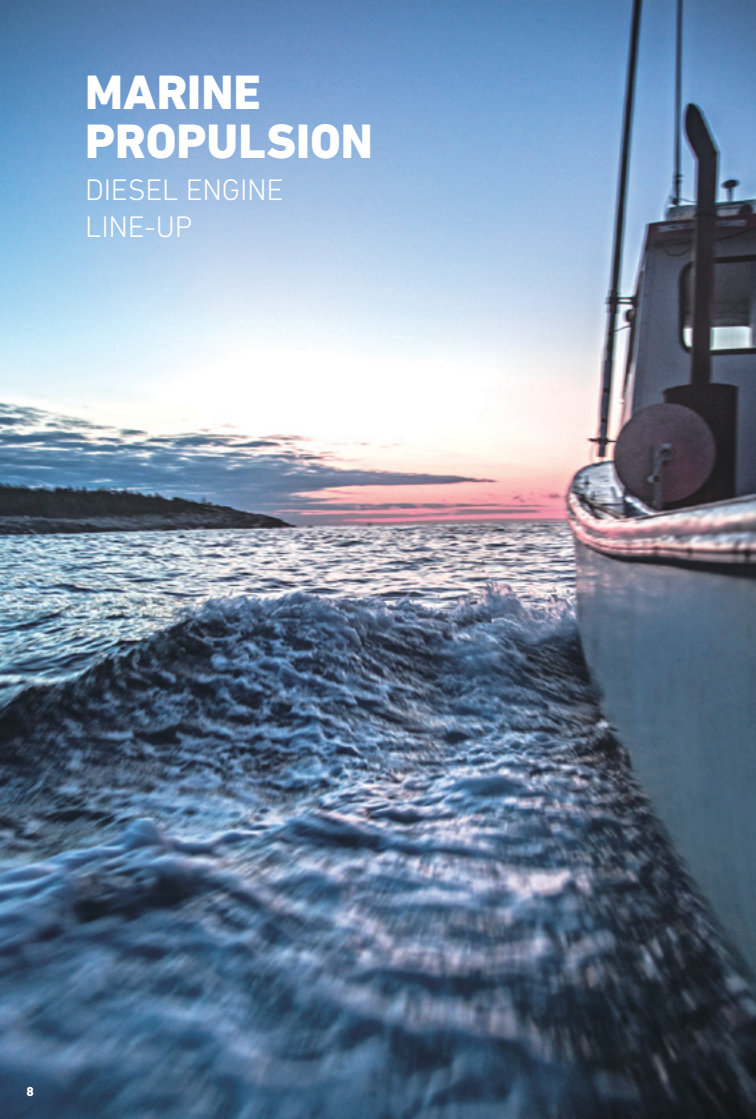

## Power Range

Model	Rating	Max Output
<b>4JHYE</b>	M-L	25.7~29.4kW
<b>4CHE3</b>	M-L	57.4~62.5kW
<b>6CHE3</b>	M-L	84.6~95.6kW
<b>6CH-HTE3</b>	M-L	125~140kW
<b>6CH-WDTE</b>	M-L	154~169kW
<b>6CH-WUTE</b>	M-L	188~206kW
<b>6CXBM-GT</b>	H	265kW
	M	294kW
	L	341kW
	S	374kW [ For planing hull ]
<b>6HA2M-WHT</b>	H	204kW
	M	257kW
<b>6HA2M-WDT</b>	M	298kW
<b>6HYM-WET</b>	H	368kW
	M	441kW
	L	478kW
	S	515kW [ For planing hull ]
<b>6AYM-WST</b>	Cont.	485kW
<b>6AYM-WET</b>	Cont.	555kW
	M	610kW
<b>6AYM-WGT</b>	L	670kW
<b>6AYEM-ST</b>	Cont.	485kW [ EPA TierIII, CHINA I&II ]
<b>6AYEM-ET</b>	Cont.	555kW [ IMO TierII ]
	H	599kW [ EPA TierIII, CHINA I&II ]
	M	610kW [ IMO TierII ]
<b>6AYEM-GT</b>	L	670kW
	S	737~749kW
	<b>12AYM-WST</b>	H
<b>12AYM-WET</b>	H	1140kW
	M	1220kW
<b>12AYM-WGT</b>	L	1340kW

0 200 400 600 800 1000 1200 1400 [ kW ]

0 200 400 600 800 1000 1200 1400 1600 1800 [ mph ]



- 4-cylinder, direct injection, heat exchanger cooling.
  - Natural aspiration.
- Yanmar YX marine gear is standard.

### Rating Conditions:

Ratings are based upon ISO 15550 reference conditions; air pressure of 100 kPa, air temperature 25°C [77°F], and 30% relative humidity.

S = For applications where use of rated power is less than 1.5 hours continuous out of every 5 hours and operation is less than 1000 hours per year.

When combined with a correctly matched propeller which allows the engine rated rpm to be achieved in a fully loaded vessel state, the reduced-power operation can be at or below 100-200 rpm of the rated speed.

L = For applications where use of rated power is less than 2 hours continuous out of every 5 hours and operation is less than 2500 hours per year.

When combined with a correctly matched propeller which allows the engine rated rpm to be achieved in a fully loaded vessel state, the reduced-power operation can be at or below 100-200 rpm of the rated speed.

M = For applications where use of rated power is less than 8 hours continuous out of every 12 hours and operation is less than 4000 hours per year.

When combined with a correctly matched propeller which allows the engine rated rpm to be achieved in a fully loaded vessel state, the reduced-power operation can be at or below 100-120 rpm of the rated speed.

H = For applications where use of rated power is less than 10 hours continuous out of every 12 hours and operation is less than 6000 hours per year.

When combined with a correctly matched propeller which allows the engine rated rpm to be achieved in a fully loaded vessel state, the reduced-power operation can be at or below 100-200 rpm of the rated speed.

C = This application is No limit in regard to annual maximum operation hours per year, continuous operation hours and load factor.

\* Please ask Yanmar or local distributor for the detail of each model.

Fuel rates: Specific gravity 840g/liter, low calorific value 42700kj/kg (10200kcal/kg), Cetane No.45.

Rating	Light Duty		Medium Duty	Heavy Duty	
	S-rating	L-rating	M-rating	H-rating	Continuous
Annual maximum operation hours/year	1000hrs or below	2500hrs or below	4000hrs or below	6000hrs or below	No Limit
Continuous operation hours	1.5hrs/5hrs or below	2hrs/5hrs or below	8hrs/12hrs or below	10hrs/12hrs or below	No Limit
Load factor	30% or below	40% or below	60% or below	80% or below	No Limit

Note: This rating definition apply for new engine that sold after 1st April 2015.

Note: All Data Subject to Change Without Notice.  
Photograph may show optional equipment.

### Specifications

Model	4JHYE	
Number of cylinders	4 in-line	
Bore × stroke	mm 78 × 86	
Displacement	lit. 1.644	
Rated output	kW(mhp)/rpm M : 25.7(35)/3400 L : 29.4(38)/3600	
Combustion system	Direct injection	
Aspiration	Natural aspirated	
Starting system	Electric motor (12V 1.8kW)	
Cooling system	Heat exchanger	
Marine gear	Hydraulic	
Dry mass	kg 243 with YX-10	
Dimensions [ L×W×H ]	mm 916×545×659 with YX-10	

### Dimensions [ mm ]

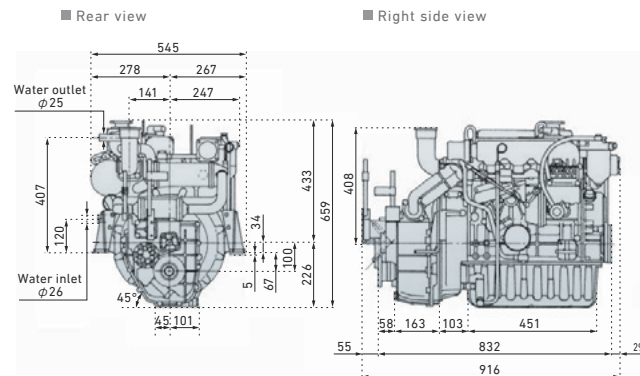

# 4CHE3 / 6CHE3

M·L-rating 57.4~95.6kW [78~130mhp]



- Direct injection, heat exchanger cooling.
- Natural aspirated 4- and 6-cylinder.
- Durable hydraulic marine gear.

## Specifications

Model	4CHE3		6CHE3	
Number of cylinders	4 in-line		6 in-line	
Bore × stroke	mm 105 × 125			
Displacement	lit. 4.330		6.494	
Rated output	M : 57.4[78]/2550		M : 84.6[115]/2550	
	L : 62.5[85]/2600		L : 95.6[130]/2600	
Combustion system	Direct injection			
Aspiration	Natural aspirated			
Starting system	Electric starting motor [24V 4.0kW]			
Cooling system	Heat exchanger			
Marine gear	Hydraulic			
Size of flywheel housing and flywheel	SAE #3 and 11-1/2 in.			
Dry mass	kg 570		700	
Dimensions [L×W×H]	mm 1258×688×1022 with YX30		1496×690×1018 with YX30	

## Marine gear specifications / Engine model : 4CHE3 · 6CHE3

Model	YX-30			
Type	Hydraulic multi-disc clutch, wet type			
Reduction ratio [Ahead]	2.03 2.55 2.96 3.48			
Direction of rotation [propeller shaft]	Clockwise or counter-clockwise viewed from stern			
Dry weight	kg 70			

## Performance curves

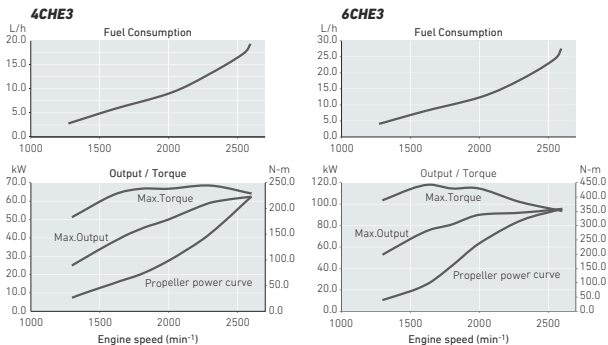

## Dimensions [ mm ]

■ Engine only / Front view

■ Engine only / Left side view

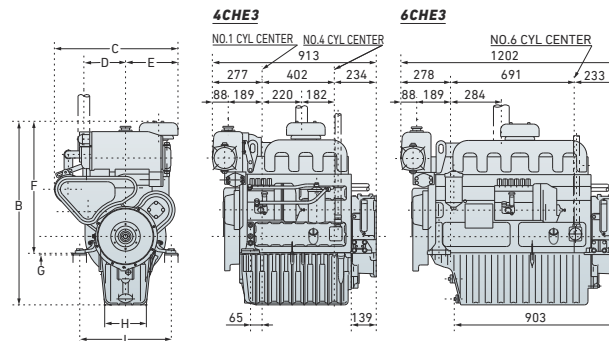

■ With YX-30 gearbox / Rear view

■ With YX-30 gearbox / Left side view

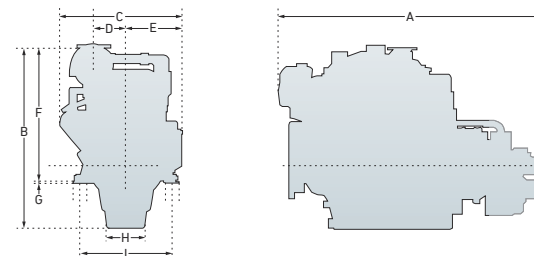

Model	A	B	C	D	E	F	G	H	I
4CHE3×YX-30-2	1258	1022	688	232	292	735	9	232	510
6CHE3×YX-30-2	1496	1018	690	233	300	737	9	233	550

— Marine gear

# 6CH-HTE3

M·L-rating 125~140kW [170~190mhp]



- Direct injection, heat exchanger cooling.
- Turbocharger + intercooler.
- Durable hydraulic marine gear.

## Specifications

Model	<b>6CH-HTE3</b>	
Number of cylinders	6 in-line	
Bore × stroke	m.m	105 × 125
Displacement	lit.	6.494
Rated output	M : 125[170]/2550 L : 140[190]/2600	
Combustion system	Direct injection	
Aspiration	Turbocharger + intercooler	
Starting system	Electric starting motor [24V 4.0kW]	
Cooling system	Heat exchanger	
Marine gear	Hydraulic	
Size of flywheel housing and flywheel	SAE #3 and 11-1/2 in.	
Dry mass	kg	795 [YX-50S] • 895 [YX-71]
Dimensions [ L×W×H ]	m.m	1575×736×1096 [YX-50S] • 1600×736×1096 [YX-71]

## Marine gear specifications / Engine model : 6CH-HTE3

Model	<b>YX-50S</b>	<b>YX-71</b>
Type	Hydraulic multi-disc clutch, wet type	
Reduction ratio [Ahead]	2.03 2.48 2.88	3.53
Direction of rotation [propeller shaft]	Clockwise or counter-clockwise viewed from stern	
Dry weight	kg	120
		220

## Performance curves

### 6CH-HTE3

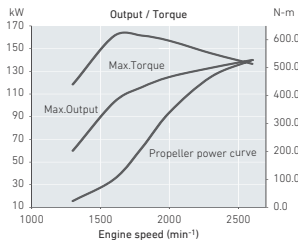
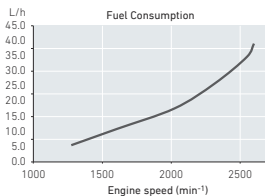

## Dimensions [ mm ]

■ Engine only / Front view

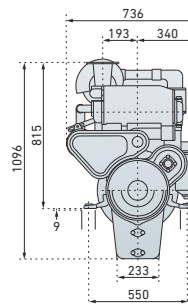

■ Engine only / Left side view

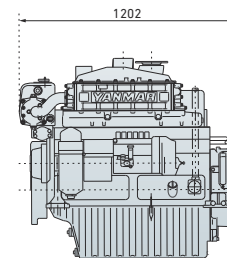

■ With gearbox / Rear view

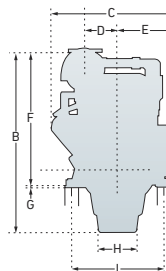

■ With gearbox / Left side view

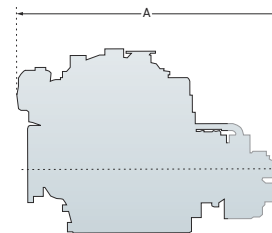

Model	A	B	C	D	E	F	G	H	I
<b>6CH-HTE3×YX-50S</b>	1575	1096	736	193	340	815	9	233	550
<b>6CH-HTE3×YX-71</b>	1600	1096	736	193	340	815	9	233	550

– Marine gear



# 6CH-WDTE

M·L-rating 154~169kW [209~230mhp]



- Direct injection, heat exchanger cooling.
- Turbocharger + intercooler.
- Durable hydraulic marine gear.
- 6CH-WDTE conform to IMO Tier II emissions regulations.

## Specifications

Model	6CH-WDTE	
Number of cylinders	6 in-line	
Bore × stroke	mm	105 × 125
Displacement	lit.	6.494
Rated output	M : 154(209)/2550 L : 169(230)/2600	
Combustion system	Direct injection	
Aspiration	Turbocharger + intercooler	
Starting system	Electric starting motor [24V 4.0kW]	
Cooling system	Heat exchanger	
Marine gear	Hydraulic	
Size of flywheel housing and flywheel	SAE #3 and 11-1/2 in.	
Dry mass	kg	900
Dimensions [ L×W×H ]	mm	1600×736×1096

## Marine gear specifications / Engine model : 6CH-WDTE

Model	YX-71			
Type	Hydraulic multi-disc clutch, wet type			
Reduction ratio [Ahead]	2.07	2.58	2.91	3.53
Direction of rotation [propeller shaft]	Clockwise or counter-clockwise viewed from stern			
Dry weight	kg	220		

## Performance curves

### 6CH-WDTE

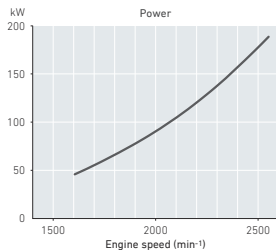
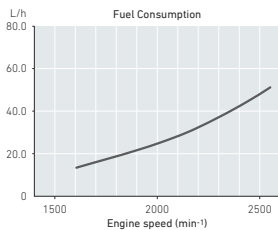

## Dimensions [ mm ]

■ Engine only / Front view

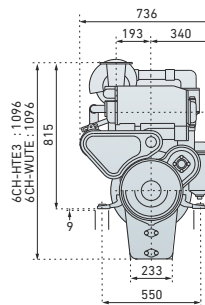

■ Engine only / Left side view

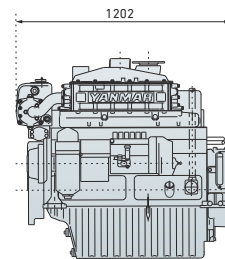

■ With gearbox / Rear view

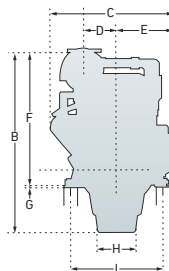

■ With gearbox / Left side view

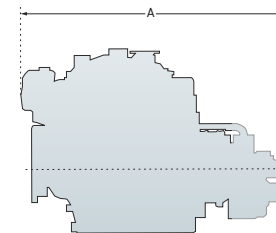

— Marine gear

Model	A	B	C	D	E	F	G	H	I
6CH-WDTE-YX-71	1600	1096	736	193	340	815	9	233	550

— Marine gear

# 6CH-WUTE

M·L-rating 188~206kW [255~280hp]



- Direct injection, heat exchanger cooling.
- Turbocharger + intercooler.
- Durable hydraulic marine gear.
- 6CH-WUTE conform to IMO Tier II emissions regulations.

## Specifications

Model	6CH-WUTE	
Number of cylinders	6 in-line	
Bore × stroke	mm	105 × 125
Displacement	lit.	6.494
Rated output	M : 188[255]/2550 L : 206[280]/2600	
	kW[mhp]/rpm	
Combustion system	Direct injection	
Aspiration	Turbocharger + intercooler	
Starting system	Electric starting motor [24V 4.0kW]	
Cooling system	Heat exchanger	
Marine gear	Hydraulic	
Size of flywheel housing and flywheel	SAE #3 and 11-1/2 in.	
Dry mass	kg	940
Dimensions [ L×W×H ]	mm	1600×736×1096

## Marine gear specifications / Engine model : 6CH-WUTE

Model	YX-71	
Type	Hydraulic multi-disc clutch, wet type	
Reduction ratio [Ahead]	2.07 2.58 2.91 3.53	
Direction of rotation [propeller shaft]	Clockwise or counter-clockwise viewed from stern	
Dry weight	kg	220

## Performance curves

### 6CH-WUTE

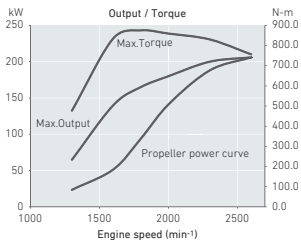
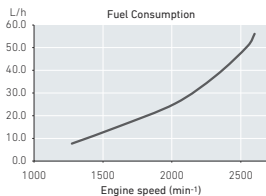

## Dimensions [ mm ]

■ Engine only / Front view

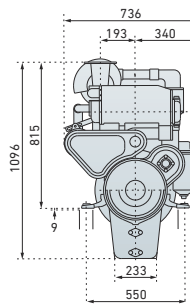

■ Engine only / Left side view

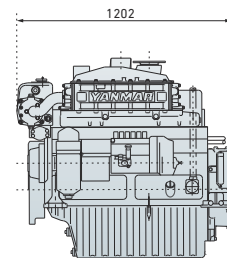

■ With gearbox / Rear view

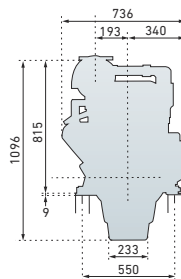

■ With gearbox / Left side view

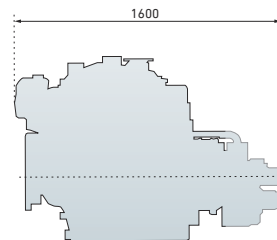

— Marine gear

# 6CXBM-GT

H-rating 265kW [360mhp]

M-rating 294kW [400mhp]



- 6-cylinder, direct injection, heat exchanger cooling.
- Turbocharger + intercooler.
- Available either with marine gear or without marine gear.
- 4-valves per cylinder for higher combustion efficiency.
- Conform to IMO Tier II emissions regulations.

## Specifications

Model	6CXBM-GT	
Number of cylinders	6 in-line	
Bore × stroke	mm 110 × 130	
Displacement	lit. 7.413	
Rated output	H : 265[360]/2400 M : 294[400]/2500	
Combustion system	Direct injection	
Aspiration	Turbocharger + intercooler	
Starting system	Electric starting motor [24V 5.0kW]	
Cooling system	Heat exchanger	
Size of flywheel housing and flywheel	SAE #3 and 11-1/2 in.	
Dry mass	kg 856	
Dimensions [L×W×H]	mm 1390×901×989	

## Marine gear specifications / Engine model : 6CXBM-GT

Model	YX-80	
Type	Hydraulic multi-disc clutch, wet type	
Reduction ratio [Ahead]	2.07 2.58 2.91	
Direction of rotation [propeller shaft]	Clockwise or counter-clockwise viewed from stern	
Dry weight	kg 204	

## Performance curves

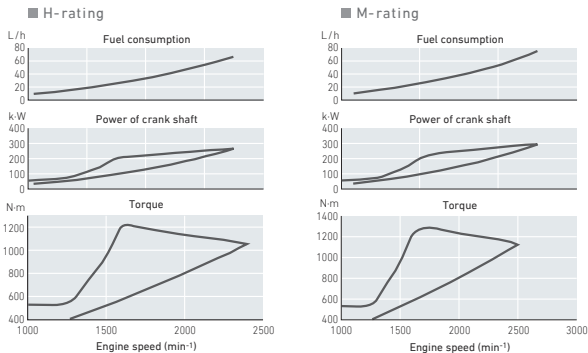

## Dimensions [ mm ]

■ Engine only / Front view

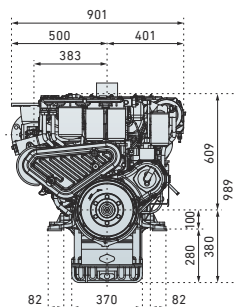

■ Engine only / Right side view

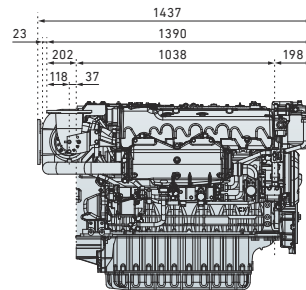

■ With YX80 gearbox / Rear view

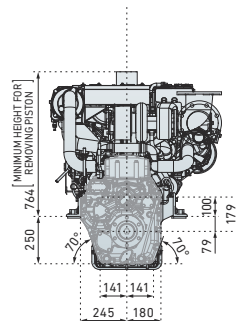

■ With YX80 gearbox / Right side view

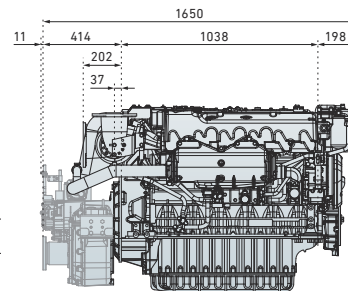

— Marine gear

# 6CXBM-GT

L-rating 341kW [464mhp]

S-rating 374kW [509mhp] (For planing hull)



- 6-cylinder, direct injection, heat exchanger cooling.
- Turbocharger + intercooler.
- Available either with marine gear or without marine gear.
- 4-valves per cylinder for higher combustion efficiency.
- Conform to IMO Tier II emissions regulations.

## Specifications

Model	6CXBM-GT	
Number of cylinders	6 in-line	
Bore × stroke	110 × 130	
Displacement	lit. 7.413	
Rated output	L : 341[464]/2700 S : 374[509]/2700	
Combustion system	Direct injection	
Aspiration	Turbocharger + intercooler	
Starting system	Electric starting motor [24V 5.0kW]	
Cooling system	Heat exchanger	
Size of flywheel housing and flywheel	SAE #3 and 11-1/2 in.	
Dry mass	kg 856	
Dimensions [L×W×H]	mm 1390×901×989	

## Marine gear specifications / Engine model : 6CXBM-GT

Model	YX-80	
Type	Hydraulic multi-disc clutch, wet type	
Reduction ratio [Ahead]	2.07 2.58 2.91	
Direction of rotation [propeller shaft]	Clockwise or counter-clockwise viewed from stern	
Dry weight	kg 204	

## Performance curves

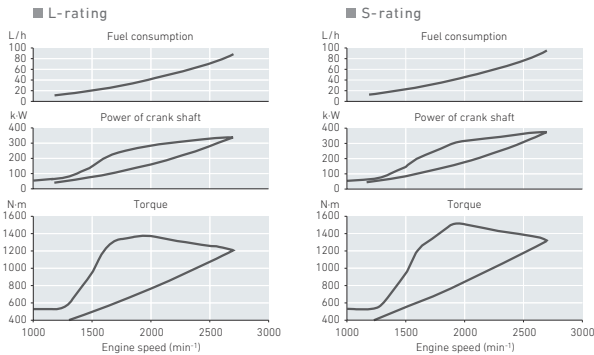

## Dimensions [ mm ]

■ Engine only / Front view

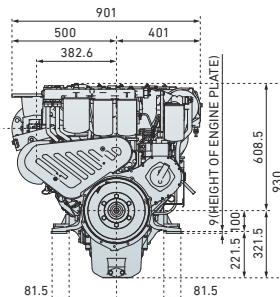

■ Engine only / Left side view

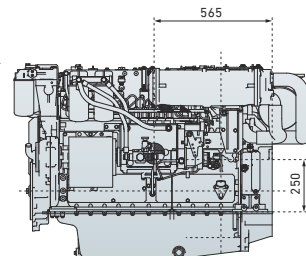

■ Engine only / Rear view

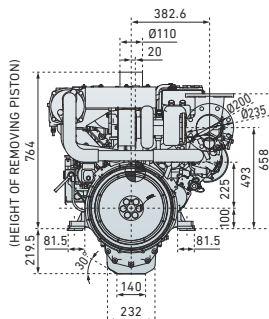

■ Engine only / Right side view

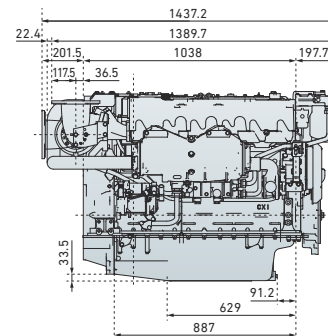

# 6HA2M-WHT

H-rating 204kW [278mhp]

M-rating 257kW [350mhp]



- 6-cylinder, direct injection, heat exchanger cooling.
- Turbocharger + intercooler models.
- Available either with marine gear or without marine gear.
- Conform to IMO Tier II emissions regulations.

## Specifications

Model	6HA2M-WHT	
Number of cylinders	6 in-line	
Bore × stroke	mm 130 × 165	
Displacement	lit. 13.140	
Rated output	H : 204[278]/1880 M : 257[350]/1950	
Combustion system	Direct injection	
Aspiration	Turbocharger + intercooler	
Starting system	Electric starting motor [24V 6.0kW]	
Cooling system	Heat exchanger	
Size of flywheel housing and flywheel	SAE #1 and 14 in.	
Dry mass	kg 1455	
Dimensions [L×W×H]	mm 1598×1016×1260	

## Marine gear specifications / Engine model : 6HA2M-WHT

Model	YX-120			YX-120L	
Type	Hydraulic multi-disc clutch, wet type				
Reduction ratio [Ahead]	2.03	2.57	3.04	3.55	4.00 4.59
Direction of rotation [propeller shaft]	Clockwise or counter-clockwise				
Dry weight	kg 315			411	

## Performance curves

■ H-rating

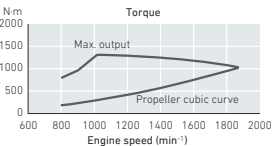
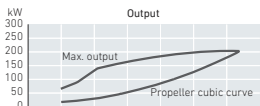
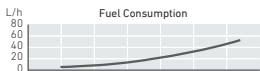

■ M-rating

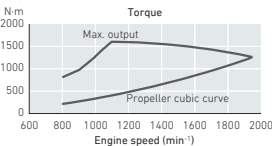
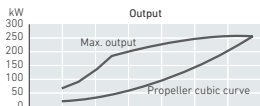
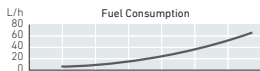

## Dimensions [ mm ]

■ Engine only / Front view

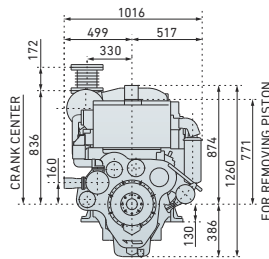

■ Engine only / Right side view

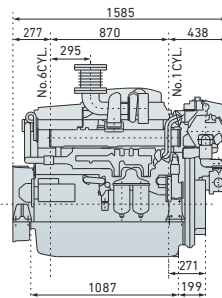

■ With YX120L gearbox / Front view

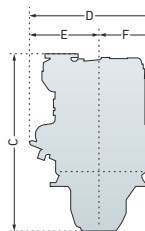

■ With YX120L gearbox / Left side view

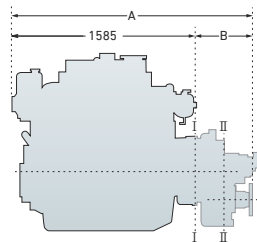

Model	A	B	C	D	E	F
6HA2M-WHT-YX-120	2005	420	1272	1016	499	517
6HA2M-WHT-YX-120L	2039	454	1384	1016	499	517

— Marine gear

# 6HA2M-WDT

M-rating 298kW [405mhp]



- 4 valves per cylinder for higher combustion efficiency.
- Turbocharger + intercooler models.
- Available either with marine gear or without marine gear.
- Conform to IMO Tier II emissions regulations.

## Specifications

Model	6HA2M-WDT	
Number of cylinders	6 in-line	
Bore × stroke	mm	130 × 165
Displacement	lit.	13.140
Rated output	kW[mhp]/rpm	M : 298[405]/1950
Combustion system	Direct injection	
Aspiration	Turbocharger + intercooler	
Starting system	Electric starting motor [24V 6.0kW]	
Cooling system	Heat exchanger	
Size of flywheel housing and flywheel	SAE #1 and 14 in.	
Dry mass	kg	1465
Dimensions [ L×W×H ]	mm	1585×1036×1260

## Marine gear specifications / Engine model : 6HA2M-WDT

Model	YX-120		YX-120L			
Type	Hydraulic multi-disc clutch, wet type					
Reduction ratio [Ahead]	2.03	2.57	3.04	3.46	4.00	4.59
Direction of rotation [propeller shaft]	Clockwise or counter-clockwise					
Dry weight	kg	315		411		

## Performance curves

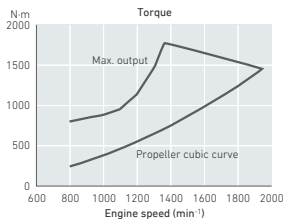
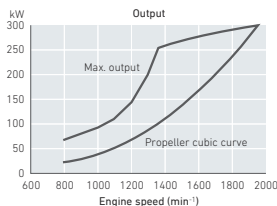
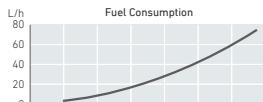

## Dimensions [ mm ]

■ Engine only / Front view

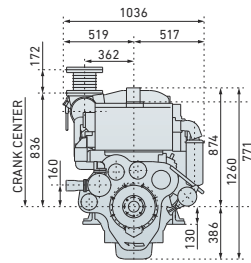

■ Engine only / Right side view

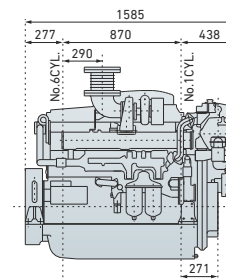

■ With YX120L gearbox / Front view

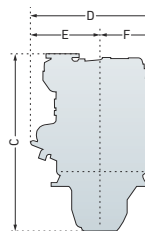

■ With YX120L gearbox / Left side view

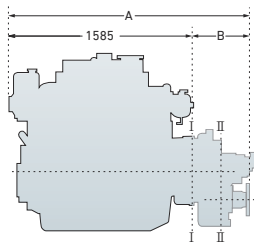

Model	A	B	C	D	E	F
6HA2M-WDT×YX-120	2005	420	1272	1036	519	517
6HA2M-WDT×YX-120L	2039	454	1384	1036	519	517

– Marine gear

# 6HYM-WET

H-rating 368kW [500mhp]



- 6-cylinder, direct injection, heat exchanger cooling.
- Twin-turbocharger + intercooler.
- Available either with marine gear or without marine gear.
- 4-valves per cylinder for higher combustion efficiency.
- Conform to IMO Tier II emissions regulations.

## Specifications

Model	6HYM-WET H-rating	
Number of cylinders	6 in-line	
Bore × stroke	mm	132.9 × 165
Displacement	lit.	13.733
Rated output	kW[mhp]/rpm	368[500]/1950
Combustion system	Direct injection	
Aspiration	Turbocharger + intercooler	
Starting system	Electric starting motor [24V 6.0kW]	
Cooling system	Heat exchanger	
Size of flywheel housing and flywheel	SAE #1 and 14 in.	
Dry mass	kg	1385 [without marine gear]
Dimensions [ L×W×H ]	mm	1556×1014×1133

## Marine gear specifications / Engine model : 6HYM-WET H-rating

Model	YXH-160		YX-161L	
Type	Hydraulic multi-disc clutch			
Reduction ratio [Ahead]	1.97	2.46	3.65	4.08
	3.05		4.55	
Direction of rotation [propeller shaft]	Clockwise or counter-clockwise			
Dry weight	kg	396	620	

## Performance curves

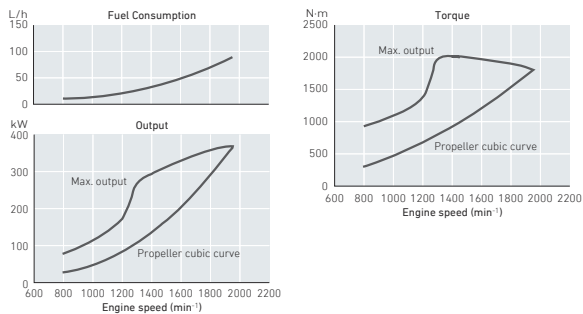

## Dimensions [ mm ]

■ Engine only / Front view

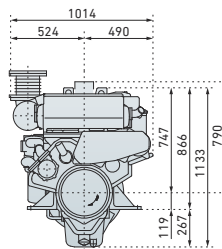

■ Engine only / Right side view

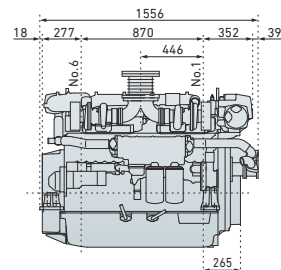

■ With YX161L gearbox / Rear view

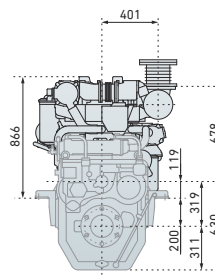

■ With YX161L gearbox / Right side view

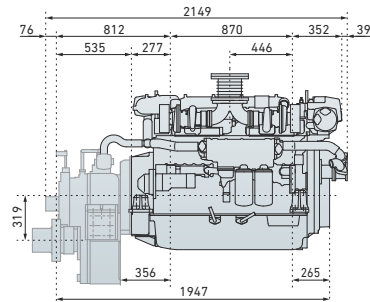

– Marine gear

# 6HYM-WET

M-rating **441kW [600mhp]**

L-rating **478kW [650mhp]**



- 6-cylinder, direct injection, heat exchanger cooling.
- Twin-turbocharger + intercooler.
- Available either with marine gear or without marine gear.
- 4-valves per cylinder for higher combustion efficiency.
- Conform to IMO Tier II emissions regulations.

## Specifications

Model	<b>6HYM-WET</b>	
Number of cylinders	6 in-line	
Bore × stroke	m.m	132.9 × 165
Displacement	lit.	13.733
Rated output	kW[mhp]/rpm	M : 441[600]/2100 L : 478[650]/2150
Combustion system	Direct injection	
Aspiration	Turbocharger + intercooler	
Starting system	Electric starting motor [24V 6.0kW]	
Cooling system	Heat exchanger	
Size of flywheel housing and flywheel	SAE #1 and 14 in.	
Dry mass	kg	1385 [without marine gear]
Dimensions [ L×W×H ]	m.m	1556×1014×1133

## Marine gear specifications / Engine model : 6HYM-WET M-rating / L-rating

Model	<b>YXH-160</b>	<b>YX-161L</b>
Type	Hydraulic multi-disc clutch	
Reduction ratio [Ahead]	1.97 2.46 3.05	3.65 4.08 4.55
Direction of rotation [propeller shaft]	Clockwise or counter-clockwise	
Dry weight	kg	396 620

## Performance curves

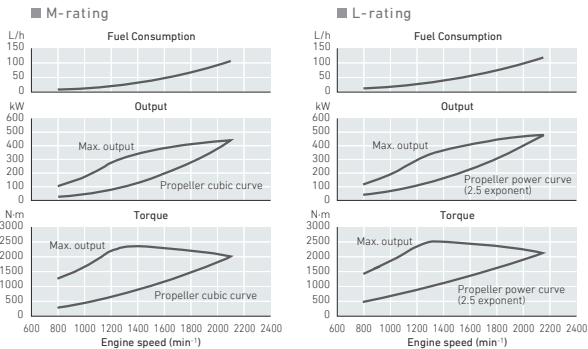

## Dimensions [ mm ]

■ Engine only / Front view

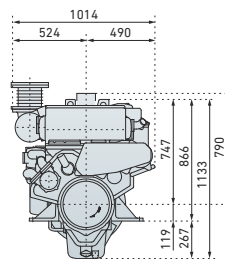

■ Engine only / Right side view

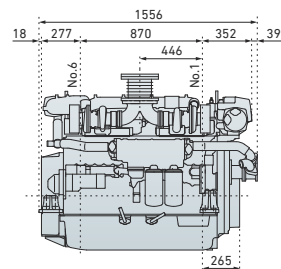

■ With YXH160 gearbox / Rear view

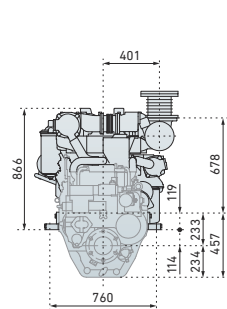

■ With YXH160 gearbox / Right side view

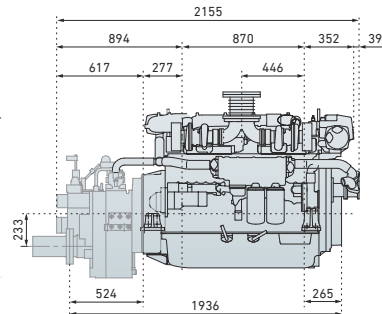

– Marine gear



# 6HYM-WET

S-rating 515kW [700mhp] (For planing hull)



- 6-cylinder, direct injection, heat exchanger cooling.
- Twin-turbocharger + intercooler.
- Available either with marine gear or without marine gear.
- 4-valves per cylinder for higher combustion efficiency.
- Conform to IMO Tier II emissions regulations.

## Specifications

Model	<b>6HYM-WET S-rating</b>	
Number of cylinders	6 in-line	
Bore × stroke	mm	132.9 × 165
Displacement	lit.	13.733
Rated output	kW[mhp]/rpm	515[700]/2200
Combustion system	Direct injection	
Aspiration	Turbocharger + intercooler	
Starting system	Electric starting motor [24V 6.0kW]	
Cooling system	Heat exchanger	
Size of flywheel housing and flywheel	SAE #1 and 14 in.	
Dry mass	kg	1385 [without marine gear]
Dimensions [ L×W×H ]	mm	1556×1014×1133

## Marine gear specifications / Engine model : 6HYM-WET S-rating

Model	<b>YXH-160</b>	
Type	Hydraulic multi-disc clutch	
Reduction ratio [Ahead]	1.97 2.46 3.05	
Direction of rotation [propeller shaft]	Clockwise or counter-clockwise	
Dry weight	kg	396

## Performance curves

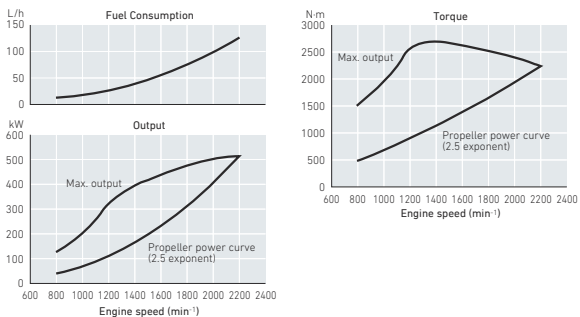

## Dimensions [ mm ]

■ Engine only / Front view

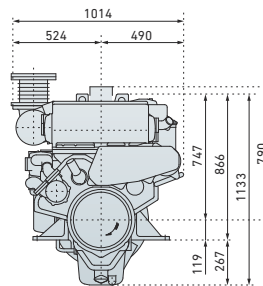

■ Engine only / Right side view

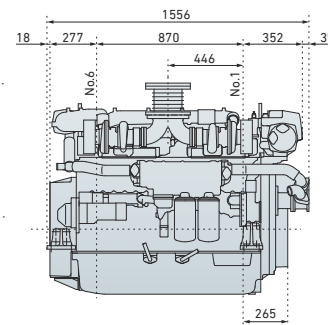

■ Engine only / Rear view

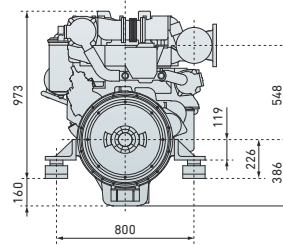

■ Engine only / Left side view

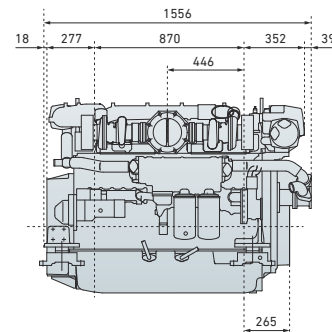

# 6AYM-WST

Continuous-rating 485kW [659mhp]



- 6-cylinder, direct injection, heat exchanger cooling.
- Turbocharger + intercooler.
- 4-valves per cylinder for higher combustion efficiency.
- Available either with marine gear or without marine gear.
- Conform to IMO Tier II emissions regulations.

## Specifications

Model	<b>6AYM-WST C-rating</b>	
Number of cylinders	6 in-line	
Bore × stroke	mm	155 × 180
Displacement	lit.	20.379
Rated output	kW[mhp]/rpm	C : 485[659]/1900
Combustion system	Direct injection	
Aspiration	Turbocharger + intercooler	
Starting system	Electric starting motor [24V 7.0kW]	
Cooling system	Heat exchanger	
Size of flywheel housing and flywheel	SAE #1 and 18 in.	
Dry mass	kg	2365 [without marine gear]
Dimensions [ L×W×H ]	mm	2000×1305×1431

## Marine gear specifications / Engine model : 6AYM-WST C-rating

Model	<b>YX-181</b>	<b>YX-180L</b>	<b>YXH-240L</b>
Type	Hydraulic multi-disc clutch		
Reduction ratio [Ahead]	2.08 2.55 3.03	3.50 4.00 4.54	4.13 4.48 4.89 5.36 5.91 6.57 6.95
Direction of rotation [propeller shaft]	Clockwise or counter-clockwise		
Dry weight	kg 560	680	1240

## Performance curves

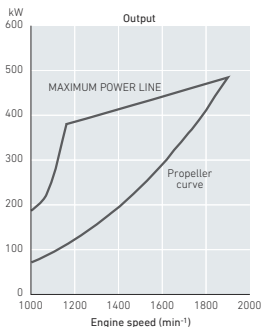
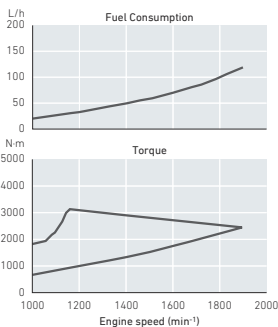

## Dimensions [ mm ]

■ With YX181 gearbox / Rear view

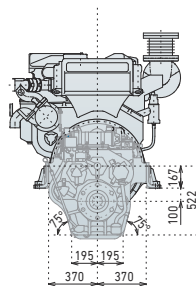

■ With YX181 gearbox / Right side view

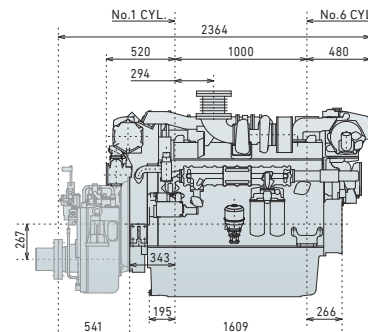

■ With YX180L gearbox / Rear view

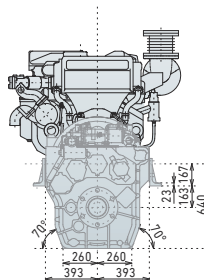

■ With YX180L gearbox / Right side view

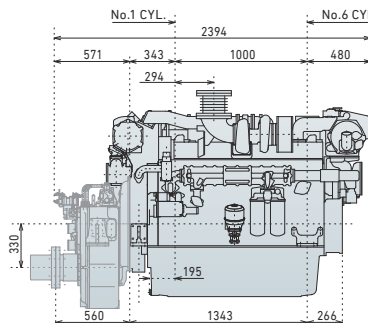

– Marine gear

# 6AYM-WET

Continuous-rating 555kW [755mhp]

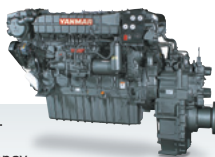

- 6-cylinder, direct injection, heat exchanger cooling.
- Turbocharger + intercooler.
- 4-valves per cylinder for higher combustion efficiency.
- Available either with marine gear or without marine gear.
- Conform to IMO Tier II emissions regulations.

## Specifications

Model	<b>6AYM-WET C-rating</b>	
Number of cylinders	6 in-line	
Bore × stroke	155 × 180	
Displacement	lit. 20.379	
Rated output	kW[mhp]/rpm C : 555[755]/1840	
Combustion system	Direct injection	
Aspiration	Turbocharger + intercooler	
Starting system	Electric starting motor [24V 7.0kW]	
Cooling system	Heat exchanger	
Size of flywheel housing and flywheel	SAE #1 and 18 in.	
Dry mass	kg 2365 [without marine gear]	
Dimensions [ L×W×H ]	mm 2000×1305×1431	

## Marine gear specifications / Engine model : 6AYM-WET C-rating

Model	<b>YXH-240</b>	<b>YXH-240L</b>
Type	Hydraulic multi-disc clutch	
Reduction ratio [Ahead]	1.95 2.27 2.56 3.03 3.48	4.13 4.48 4.89 5.36 5.91 6.57 6.95
Direction of rotation [propeller shaft]	Clockwise or counter-clockwise	
Dry weight	kg 632	1240

## Performance curves

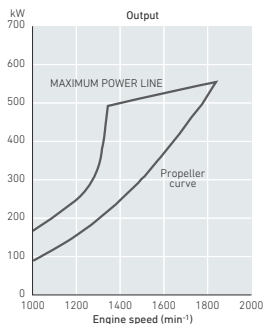
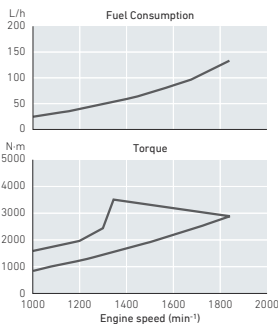

## Dimensions [ mm ]

■ Engine only / Front view

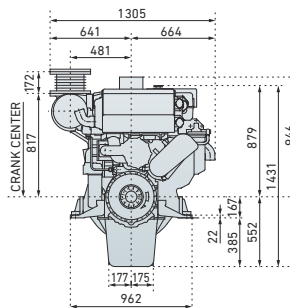

■ Engine only / Right side view

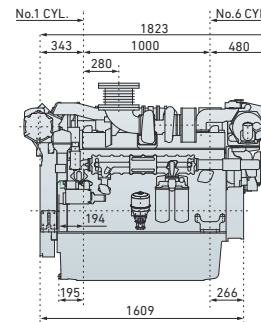

■ With YXH240L gearbox / Rear view

■ With YXH240L gearbox / Right side view

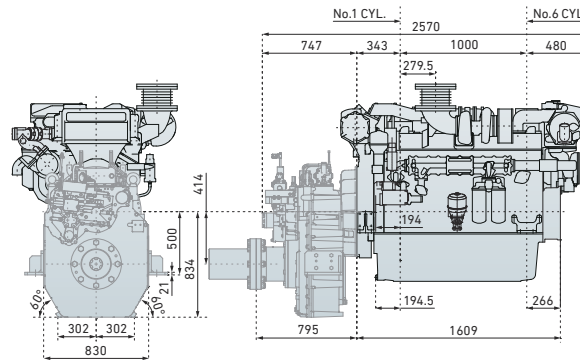

— Marine gear

# 6AYM-WET

M-rating 610kW [829mhp]



- 6-cylinder, direct injection, heat exchanger cooling.
- Turbocharger + intercooler.
- 4-valves per cylinder for higher combustion efficiency.
- Available either with marine gear or without marine gear.
- Conform to IMO Tier II emissions regulations.

## Specifications

Model	<b>6AYM-WET M-rating</b>	
Number of cylinders	6 in-line	
Bore × stroke	mm	155 × 180
Displacement	lit.	20.379
Rated output	kW[mhp]/rpm	M : 610[829]/1900
Combustion system	Direct injection	
Aspiration	Turbocharger + intercooler	
Starting system	Electric starting motor [24V 7.0kW]	
Cooling system	Heat exchanger	
Size of flywheel housing and flywheel	SAE #1 and 18 in.	
Dry mass	kg	2365 [without marine gear]
Dimensions [L×W×H]	mm	2000×1305×1431

## Marine gear specifications / Engine model : 6AYM-WET M-rating

Model	<b>YXH-240</b>	<b>YXH-240L</b>
Type	Hydraulic multi-disc clutch	
Reduction ratio [Ahead]	1.95 2.27 2.56 3.03 3.48	4.13 4.48 4.89 5.36 5.91 6.57 6.95
Direction of rotation [propeller shaft]	Clockwise or counter-clockwise	
Dry weight	kg	632

## Performance curves

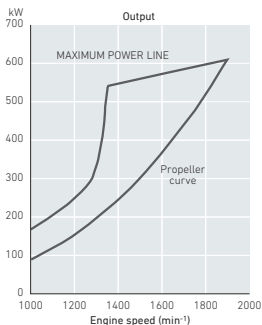
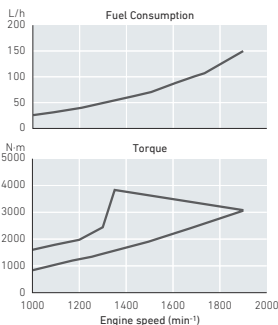

## Dimensions [ mm ]

■ Engine only / Front view

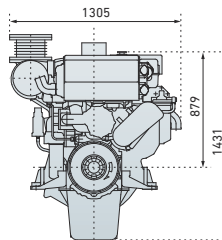

■ Engine only / Right side view

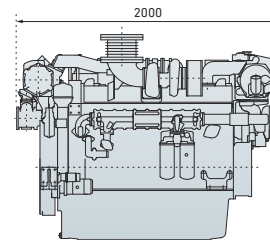

■ With YXH240 gearbox / Rear view

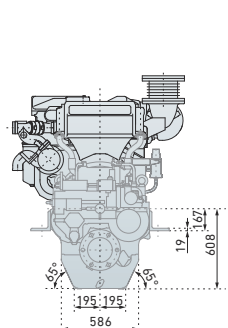

■ With YXH240 gearbox / Right side view

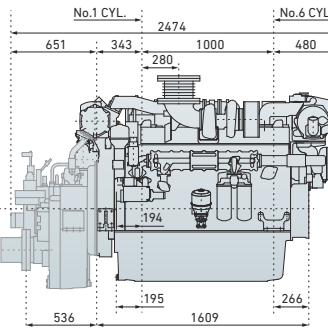

– Marine gear

# 6AYM-WGT

L-rating 670kW [911mhp]



- 6-cylinder, direct injection, heat exchanger cooling.
- Turbocharger + intercooler.
- 4-valves per cylinder for higher combustion efficiency.
- Available either with marine gear or without marine gear.
- Conform to IMO Tier II emissions regulations.

## Specifications

Model	<b>6AYM-WGT L-rating</b>	
Number of cylinders	6 in-line	
Bore × stroke	mm	155 × 180
Displacement	lit.	20.379
Rated output	kW[mhp]/rpm	L : 670[911]/1938
Combustion system	Direct injection	
Aspiration	Turbocharger + intercooler	
Starting system	Electric starting motor [24V 7.0kW]	
Cooling system	Heat exchanger	
Size of flywheel housing and flywheel	SAE #1 and 18 in.	
Dry mass	kg	2365 [without marine gear]
Dimensions [ L×W×H ]	mm	2000×1305×1431

## Marine gear specifications / Engine model : 6AYM-WGT L-rating

Model	<b>YXH-240</b>	
Type	Hydraulic multi-disc clutch	
Reduction ratio [Ahead]	1.95 2.27 2.56 3.03 3.48	
Direction of rotation [propeller shaft]	Clockwise or counter-clockwise	
Dry weight	kg	632

## Performance curves

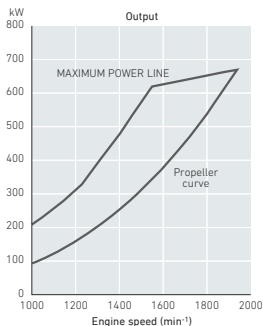
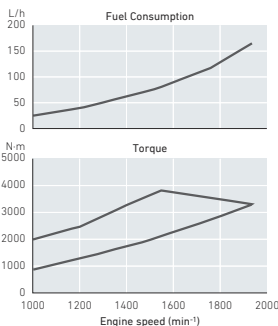

## Dimensions [ mm ]

■ Engine only / Front view

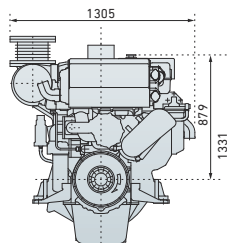

■ Engine only / Right side view [Shallow sump]

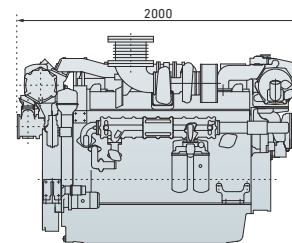

■ With YXH240 gearbox / Rear view

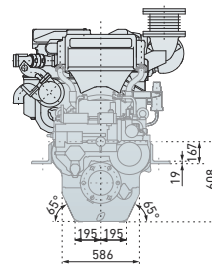

■ With YXH240 gearbox / Right side view

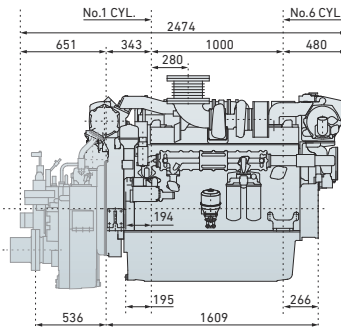

– Marine gear

# 6AYEM-ST [ EPA Tier III ]

## [ China Marine Regulation, Stage I & II ]

Continuous-rating **485kW [659mhp]**



- Common Rail system
- 6-cylinder, direct injection, heat exchanger cooling.
- Turbocharger + intercooler.
- 4-valves per cylinder for higher combustion efficiency.
- Available either with marine gear or without marine gear.
- Conform to EPA Tier III emissions regulations.

### Specifications

Model	6AYEM-ST	
Number of cylinders	6 in-line	
Bore × stroke	mm	155 × 180
Displacement	lit.	20.379
Rated output	kW[mhp]/rpm	C : 485[659]/1900
Combustion system	Direct injection	
Aspiration	Turbocharger + intercooler	
Starting system	Electric starting motor [24V 8.0kW]	
Cooling system	Heat exchanger	
Size of flywheel housing and flywheel	SAE #0 and 18 in.	
Dry mass	kg	2365 [without marine gear]
Dimensions [L×W×H]	mm	2000×1305×1531

### Marine gear specifications / Engine model : 6AYEM-ST

Model	YXH-240-7	
Type	Hydraulic multi-disc clutch	
Reduction ratio [Ahead]	1.95 2.27 2.56 3.03 3.48	
Direction of rotation [propeller shaft]	Clockwise or counter-clockwise	
Dry weight	kg	632

### Performance curves

#### ■ Continuous-rating

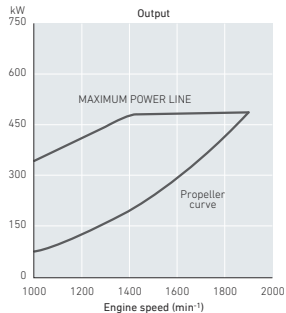
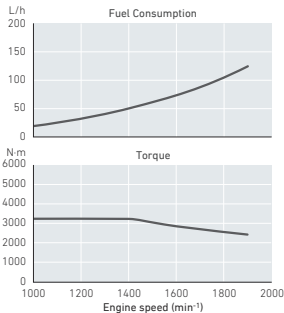

### Dimensions [ mm ]

#### ■ Engine only / Front view

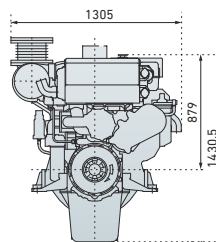

#### ■ Engine only / Right side view

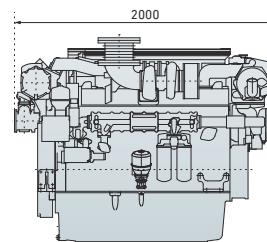

#### ■ With YXH240 gearbox / Rear view

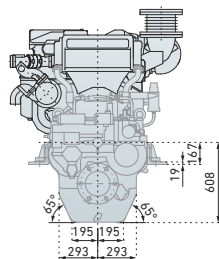

#### ■ With YXH240 gearbox / Right side view

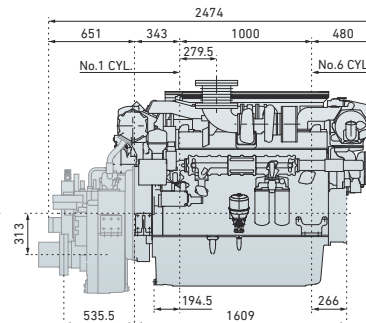

— Marine gear

# 6AYEM-ET [ IMO Tier III ]

Continuous-rating **555kW [755mhp]**

M-rating **610kW [829mhp]**



- Common Rail system
- 6-cylinder, direct injection, heat exchanger cooling.
- Turbocharger + intercooler.
- 4-valves per cylinder for higher combustion efficiency.
- Available either with marine gear or without marine gear.
- Conform to IMO Tier II emissions regulations.

## Specifications

Model	<b>6AYEM-ET</b>	
Number of cylinders	6 in-line	
Bore × stroke	mm	155 × 180
Displacement	lit.	20.379
Rated output	kW[mhp]/rpm	C : 555[755]/1840 M : 610[829]/1900
Combustion system	Direct injection	
Aspiration	Turbocharger + intercooler	
Starting system	Electric starting motor [24V 8.0kW]	
Cooling system	Heat exchanger	
Size of flywheel housing and flywheel	SAE #0 and 18 in.	
Dry mass	kg	2418 [without marine gear]
Dimensions [ L×W×H ]	mm	2000×1305×1531

## Marine gear specifications / Engine model : 6AYEM-ET

Model	<b>YXH-240-7</b>	
Type	Hydraulic multi-disc clutch	
Reduction ratio [Ahead]	1.95 2.27 2.56 3.03 3.48	
Direction of rotation [propeller shaft]	Clockwise or counter-clockwise	
Dry weight	kg	632

## Performance curves

### ■ Continuous-rating

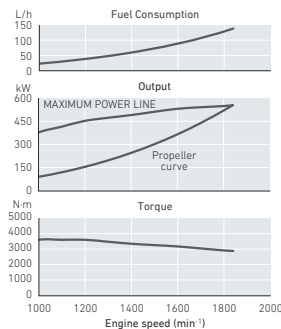

### ■ M-rating

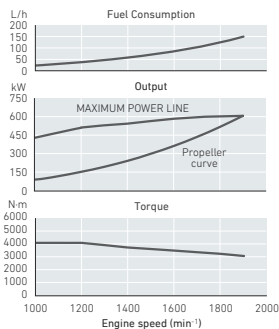

## Dimensions [ mm ]

### ■ Engine only / Front view

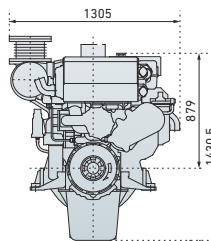

### ■ Engine only / Right side view

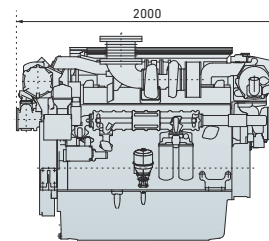

### ■ With YXH240 gearbox / Rear view

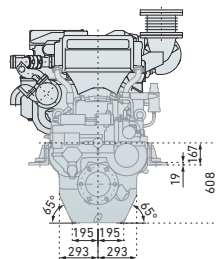

### ■ With YXH240 gearbox / Right side view

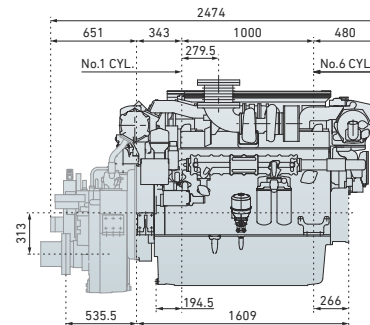

– Marine gear

# 6AYEM-ET [ EPA Tier III ] [ China Marine Regulation, Stage I & II ]

H-rating 599kW [814mhp]



- Common Rail system
- 6-cylinder, direct injection, heat exchanger cooling.
- Turbocharger + intercooler.
- 4-valves per cylinder for higher combustion efficiency.
- Available either with marine gear or without marine gear.
- Conform to EPA Tier III emissions regulations.

## Specifications

Model	6AYEM-ET	
Number of cylinders	6 in-line	
Bore × stroke	mm	155 × 180
Displacement	lit.	20.379
Rated output	kW[mhp]/rpm	H : 599[814]/1900
Combustion system	Direct injection	
Aspiration	Turbocharger + intercooler	
Starting system	Electric starting motor [24V 8.0kW]	
Cooling system	Heat exchanger	
Size of flywheel housing and flywheel	SAE #0 and 18 in.	
Dry mass	kg	2418 [without marine gear]
Dimensions [L×W×H]	mm	2000×1305×1531

## Marine gear specifications / Engine model : 6AYEM-ST

Model	YXH-240-7	
Type	Hydraulic multi-disc clutch	
Reduction ratio [Ahead]	1.95 2.27 2.56 3.03 3.48	
Direction of rotation [propeller shaft]	Clockwise or counter-clockwise	
Dry weight	kg	632

## Performance curves

■ H-rating

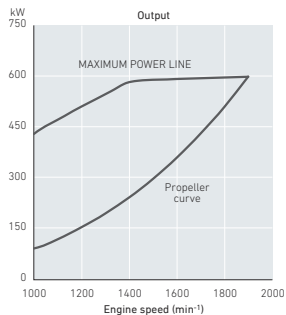
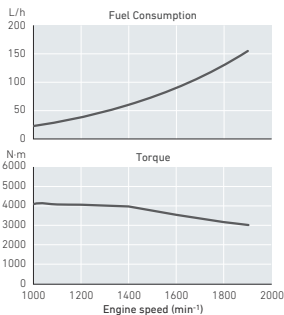

## Dimensions [ mm ]

■ Engine only / Front view

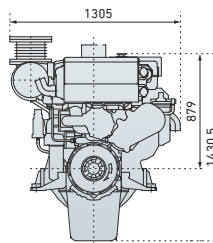

■ Engine only / Right side view

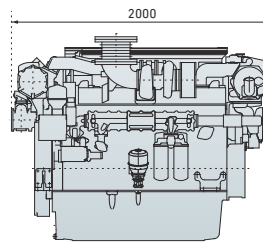

■ With YXH240 gearbox / Rear view

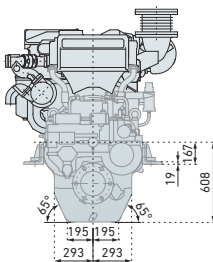

■ With YXH240 gearbox / Right side view

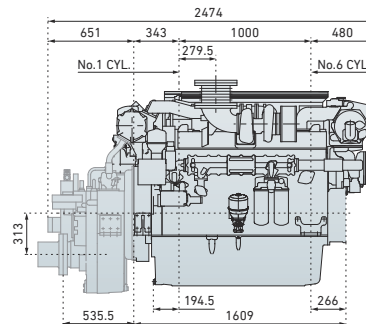

— Marine gear



# 6AYEM-GT

L-rating 670kW [911mhp] [ IMO Tier III ]

S-rating 737kW [1002mhp]

S-rating 749kW [1018mhp] [ IMO Tier III ] [ EPA Tier 4 ]



- Common Rail system
- 6-cylinder, direct injection, heat exchanger cooling.
- Turbocharger + intercooler.
- 4-valves per cylinder for higher combustion efficiency.
- Available either with marine gear or without marine gear.
- Conform to IMO Tier II emissions regulations.

## Specifications

Model		6AYEM-GT
Number of cylinders		6 in-line
Bore × stroke		155 × 180
Displacement		20.379
Rated output		L: 670[911]/1938 S: 737[1002]/2000, S: 749[1018]/2000
Combustion system		Direct injection
Aspiration		Turbocharger + intercooler
Starting system		Electric starting motor [24V 8.0kW]
Cooling system		Heat exchanger
Size of flywheel housing and flywheel		SAE #0 and 18 in.
Dry mass		2418 [without marine gear]
Dimensions [ L×W×H ]		2000×1305×1531

## Marine gear specifications / Engine model : 6AYEM-GT

Model		YXH-240-7
Type		Hydraulic multi-disc clutch
Reduction ratio [Ahead]		1.95 2.27 2.56 3.03 3.48
Direction of rotation [propeller shaft]		Clockwise or counter-clockwise
Dry weight		632

## Performance curves

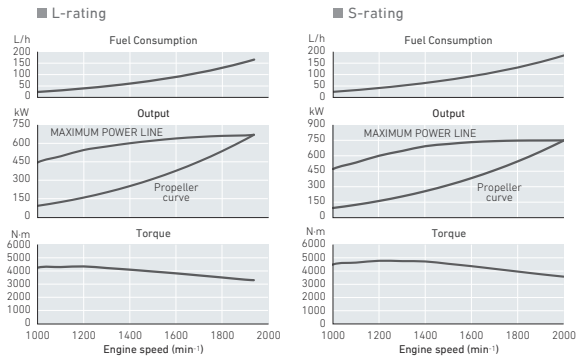

## Dimensions [ mm ]

■ Engine only / Front view

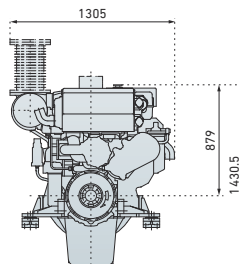

■ Engine only / Right side view [Shallow sump]

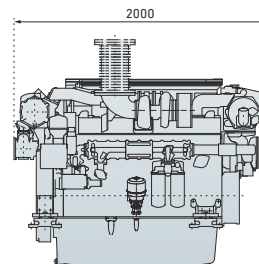

■ With YXH240 gearbox / Rear view

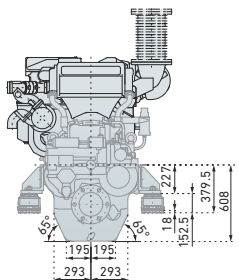

■ With YXH240 gearbox / Right side view

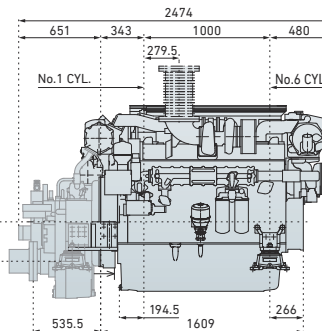

– Marine gear

# 12AYM-WST

H-rating 882kW [1199mhp]

H-rating 1030kW [1400mhp]



- V-type, 12-cylinder, direct injection, heat exchanger cooling.
- Turbocharger + intercooler.
- 4-valves per cylinder for higher combustion efficiency.
- Conform to IMO TierII emissions regulations.

## Specifications

Model	12AYM-WST H-rating	
Number of cylinders	12 V-type	
Bore × stroke	mm 155 × 180	
Displacement	lit. 40.76	
Rated output	kW[mhp]/rpm H : 882[1199]/1850 H : 1030[1400]/1900	
Combustion system	Direct injection	
Aspiration	Turbocharger + intercooler	
Starting system	Electric starting motor [24V 8.0kW] × 2 or air motor × 2	
Cooling system	Constant high temperature cooling system	
Size of flywheel housing and flywheel	SAE #00 and 21 in.	
Dry mass	kg 4950 [without marine gear]	
Dimensions [L×W×H]	mm 2759×1644×1707	

## Marine gear specifications / Engine model : 12AYM-WST H-rating

Model	YXH-500-1	YXH-500L-1
Type	Hydraulic multi-disc clutch	
Reduction ratio [Ahead]	2.53 3.04 3.48	3.57 4.07 4.48 4.96
Direction of rotation [propeller shaft]	Clockwise or counter-clockwise	
Dry weight	kg 970	1620
Live PTO	-	SAE B-B, B, C-C, C

## Performance curves

■ H rating 882kW [1199mhp]

■ H rating 1030kW [1400mhp]

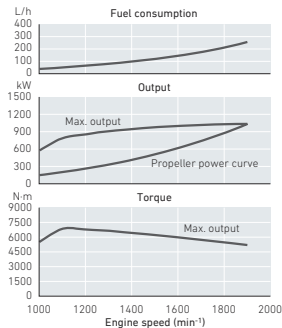
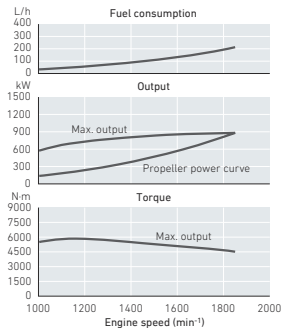

## Dimensions [ mm ]

■ Engine only / Front view

■ Engine only / Right side view

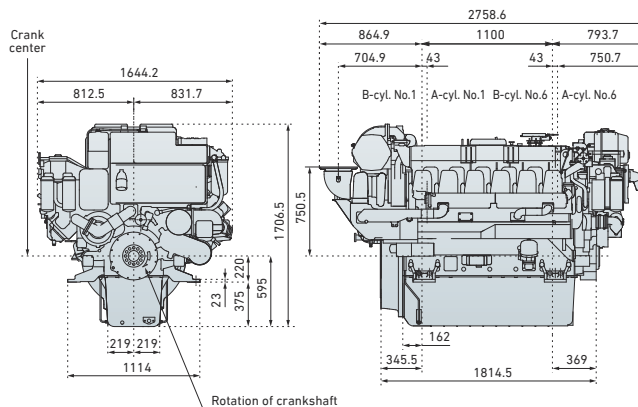

Rotation of crankshaft

# 12AYM-WET

H-rating 1140kW [1550mhp]

M-rating 1220kW [1659mhp]



- V-type, 12-cylinder, direct injection, heat exchanger cooling.
- Turbocharger + intercooler.
- 4-valves per cylinder for higher combustion efficiency.
- Conform to IMO TierII emissions regulations.

## Specifications

Model	12AYM-WET H-rating / M-rating	
Number of cylinders	12 V-type	
Bore × stroke	mm 155 × 180	
Displacement	lit. 40.76	
Rated output	kW[mhp]/rpm H : 1140[1550]/1840 M : 1220[1659]/1900	
Combustion system	Direct injection	
Aspiration	Turbocharger + intercooler	
Starting system	Electric starting motor [24V 8.0kW] × 2 or air motor × 2	
Cooling system	Constant high temperature cooling system	
Size of flywheel housing and flywheel	SAE #00 and 21 in.	
Dry mass	kg 4950 [without marine gear]	
Dimensions [L×W×H]	mm 2759×1644×1707	

## Performance curves

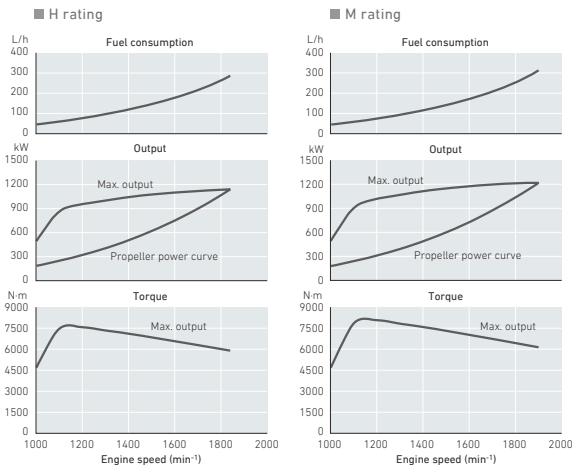

## Dimensions [ mm ]

■ Engine only / Front view

■ Engine only / Right side view

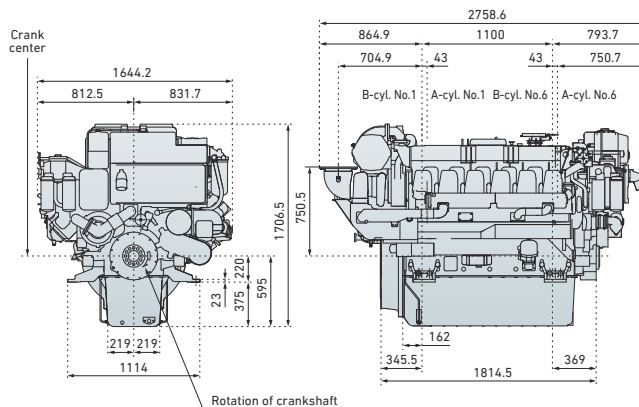

# 12AYM-WGT

L-rating 1340kW [1822mhp]



- V-type, 12-cylinder, direct injection, heat exchanger cooling.
- Turbocharger + intercooler.
- 4-valves per cylinder for higher combustion efficiency.
- Conform to IMO TierII emissions regulations.

## Specifications

Model	12AYM-WGT L-rating	
Number of cylinders	12 V-type	
Bore × stroke	mm	155 × 180
Displacement	lit.	40.76
Rated output	kW[mhp]/rpm	L : 1340[1822]/1940
Combustion system	Direct injection	
Aspiration	Turbocharger + intercooler	
Starting system	Electric starting motor [24V 8.0kW] × 2 or air motor × 2	
Cooling system	Constant high temperature cooling system	
Size of flywheel housing and flywheel	SAE #00 and 21 in.	
Dry mass	kg	4950 [without marine gear]
Dimensions [L×W×H]	mm	2759×1644×1707

## Performance curves

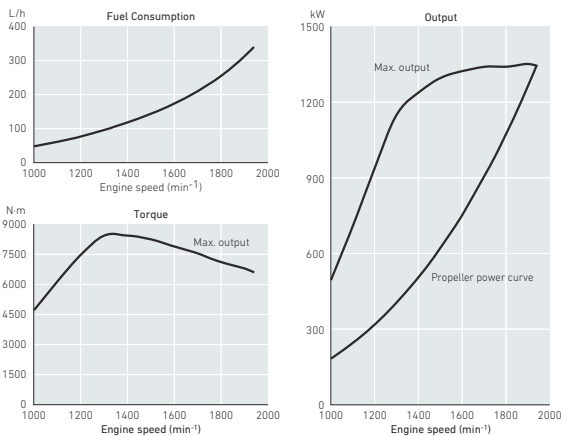

## Dimensions [ mm ]

■ Engine only / Front view

■ Engine only / Right side view

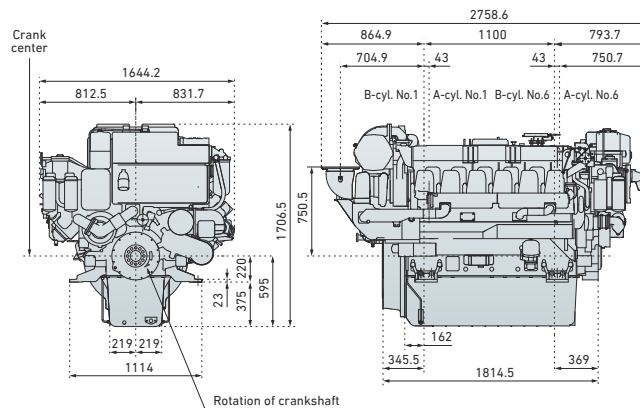

# MARINE AUXILIARY

DIESEL ENGINE  
LINE-UP



## Generator Capacity

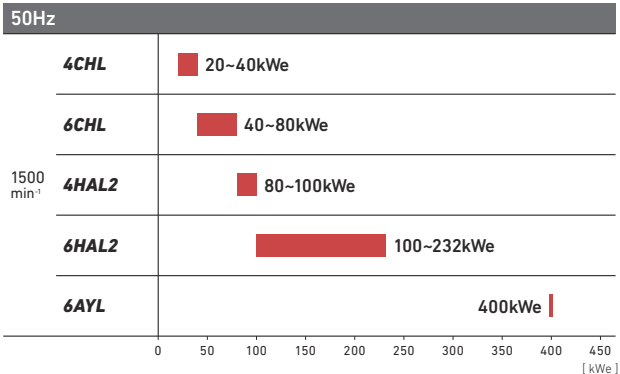
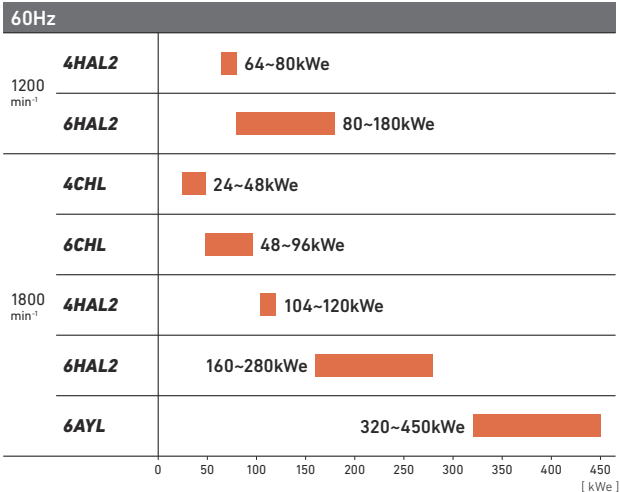

# 4CHL

Generator Capacity  
20~48kWe



## Specifications

Engine Model	4CHL-N		4CHL-TN		4CHL-TNA	
Type	Vertical, Water-cooled, 4-stroke Diesel					
No. of Cylinders	In-line 4					
Cylinder Bore x Stroke	mm 105x125					
Continuous Rated Output	27.9 [38]	36.8 [50]	36.8 [50]	45.6 [62]	45.6 [62]	54.4 [74]
Generator Capacity	20 [25]	24 [30]	32 [40]	40 [50]	40 [50]	48 [60]
Engine Speed	min <sup>-1</sup> 1500 1800 1500 1800 1500 1800					
Combustion system	Direct injection					
Starting system	Electric Starting or Air-motor starting					
Dry Weight	kg 500		520			
Total Weight [Gen.Set]	kg 940	990	1040	1800	1500	1090

The engine dry weight may differ depending upon the specifications and attached accessories.  
Above generator capacity will vary according to actual generator efficiency.  
• In case of 4CHL-TNA, continuous load operation shall be 80% or below of rated power, and 100% load operation shall be within 2 hours per 12 hours.

## Dimensions [ mm ]

Models	4CHL-N	4CHL-TN	4CHL-TNA
A	1552	1532	1572
A'	917	917	917
B	947	947	947
C	1350.5	1473	1473
D	1350	1350	1420
E	610	610	610
F	473	473	473
G	1164	1164	1164

Depending on the specifications or options that have been chosen, your model may differ slightly from the one in the photograph and outline.

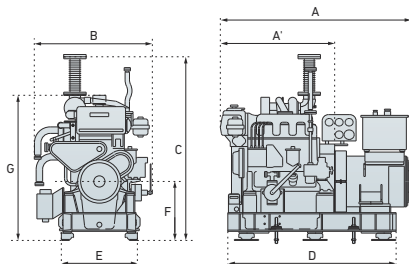

G : Minimum Height for Removing Piston ( Not included the dimension for bolt fitting to piston remove. )

# 6CHL

Generator Capacity  
40~96kWe



## Specifications

Engine Model	6CHL-N		6CHL-TN		6CHL-TNA		6CHL-HTN		6CHL-HTNA	
Type	Vertical, Water-cooled, 4-stroke Diesel									
No. of Cylinders	In-line 6									
Cylinder Bore x Stroke	mm 105x125									
Continuous Rated Output	45.6 [62]	54.4 [74]	54.4 [74]	73.6 [100]	67.7 [92]	89.7 [122]	73.6 [100]	88.3 [120]	91.9 [125]	107 [145]
Generator Capacity	40 [50]	48 [60]	48 [60]	64 [80]	60 [75]	80 [100]	64 [80]	80 [100]	80 [100]	96 [120]
Engine Speed	min <sup>-1</sup> 1500 1800 1500 1800 1500 1800 1500 1800 1500 1800									
Combustion system	Direct injection									
Starting system	Electric Starting or Air-motor starting									
Dry Weight	kg 625		645		645		675		675	
Total Weight [Gen.Set]	kg 1220	1350	1350	1350	1350	1380	1380	1540	1540	1540

The engine dry weight may differ depending upon the specifications and attached accessories.  
Above generator capacity will vary according to actual generator efficiency.  
• In case of 6CHL-TNA / 6CHL-HTNA, continuous load operation shall be 80% or below of rated power, and 100% load operation shall be within 2 hours per 12 hours.

## Dimensions [ mm ]

Models	6CHL-N	6CHL-TN	6CHL-TNA	6CHL-HTN	6CHL-HTNA
A	1861	1926	1926	1946	2051
A'	1206	1206	1206	1256	1256
B	962	962	962	962	962
C	1382	1624	1624	1624	1634
D	1650	1700	1700	1700	1900
E	640	640	640	640	640
F	474	474	474	474	484
G	1165	1165	1165	1165	1175

Depending on the specifications or options that have been chosen, your model may differ slightly from the one in the photograph and outline.

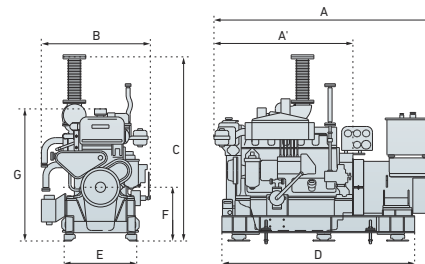

G : Minimum Height for Removing Piston ( Not included the dimension for bolt fitting to piston remove. )

# 4HAL2

Generator Capacity  
64~120kWe



## Specifications

Engine Model	4HAL2-TN1			4HAL2-TN		4HAL2-WT
Type	Vertical, Water-cooled, 4-stroke Diesel					
No. of Cylinders	In-line 4					
Cylinder Bore × Stroke	mm 130×165					
Continuous Rated Output	72 [98]	89 [121]	116 [157]	90 [122]	115 [156]	135 [183]
Generator Capacity	64 [80]	80 [100]	104 [130]	80 [100]	100 [125]	120 [150]
Engine Speed	min <sup>-1</sup> 1200 1500 1800 1200 1500 1800					
Combustion system	Direct injection					
Starting system	Electric Starting or Air-motor starting					
Dry Weight	kg 1030					
Total Weight [Gen.Set]	kg 1855					

The engine dry weight may differ depending upon the specifications and attached accessories.  
Above generator capacity will vary according to actual generator efficiency.

## Dimensions [ mm ]

Models	4HAL2-TN1	4HAL2-TN	4HAL2-WT
A	2070	2070	2070
A'	1245	1245	1245
B	1117	1117	1117
C	1685	1685	1685
D	1600	1600	1600
E	820	820	820
F	529	529	529
G	1312	1312	1312

Depending on the specifications or options that have been chosen,  
your model may differ slightly from the one in the photograph and outline.

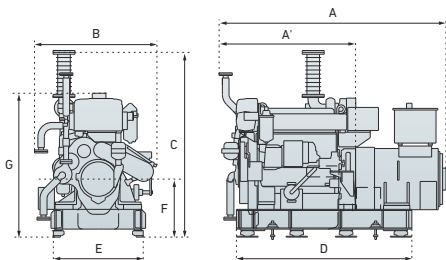

G : Minimum Height for Removing Piston ( Not included the dimension for bolt fitting to piston remove. )

# 6HAL2

Generator Capacity  
80~280kWe



## Specifications

Engine Model	6HAL2-N		6HAL2-TN	6HAL2-WT	6HAL2-WHT	6HAL2-WDT					
Type	Vertical, Water-cooled, 4-stroke Diesel										
No. of Cylinders	In-line 6										
Cylinder Bore × Stroke	mm 130×165										
Continuous Rated Output	90 [122]	115 [156]	120 [163]	150 [204]	180 [244]	160 [217]	220 [299]	265 [360]	200 [271]	255 [346]	305 [414]
Generator Capacity	80 [100]	100 [125]	104 [130]	136 [170]	160 [200]	144 [180]	200 [250]	240 [300]	180 [225]	232 [290]	280 [350]
Engine Speed	min <sup>-1</sup> 1200 1500 1200 1500 1800 1200 1500 1800 1200 1500 1800										
Combustion system	Direct injection										
Starting system	Electric Starting or Air-motor starting										
Dry Weight	kg 625		kg 1422		kg 1437		kg 1447		kg 2850		
Total Weight [Gen.Set]	kg 1220		kg 2410		kg 2750		kg 2750		kg 2850		

The engine dry weight may differ depending upon the specifications and attached accessories.  
Above generator capacity will vary according to actual generator efficiency.

## Dimensions [ mm ]

Models	6HAL2-N	6HAL2-TN	6HAL2-WT	6HAL2-WHT	6HAL2-WDT
A	2499	2499	2499	2574	2684
A'	1589	1589	1589	1589	1589
B	1164	1164	1164	1164	1164
C	1654	1774	1774	1804	1804
D	2100	2100	2100	2200	2200
E	820	820	820	820	820
F	544	544	544	544	544
G	1327	1327	1327	1327	1327

Depending on the specifications or options that have been chosen,  
your model may differ slightly from the one in the photograph and outline.

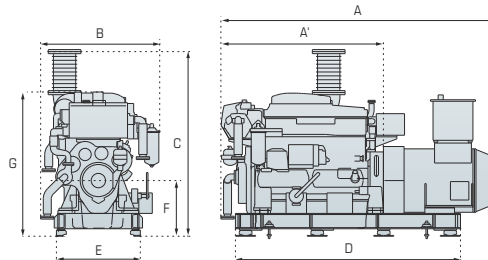

G : Minimum Height for Removing Piston ( Not included the dimension for bolt fitting to piston remove. )

# 6AYL [ IMO Tier III ]

Generator Capacity  
320~450kWe



## Specifications

Engine Model	6AYL-WST		6AYL-WET	
Type	Vertical, Water-cooled, 4-stroke Diesel			
No. of Cylinders	In-line 4			
Cylinder Bore × Stroke mm	155×180			
Continuous Rated Output kW[PS]	353 [480]	438 [596]	491 [668]	
Generator Capacity kWe[kVA]	320 [400]	400 [500]	450 [562.5]	
Engine Speed min <sup>-1</sup>	1800	1500	1800	
Combustion system	Direct injection			
Starting system	Electric Starting or Air-motor starting			
Dry Weight kg	2475		2475	
Total Weight [Gen.Set] kg	4600		4750	

The engine dry weight may differ depending upon the specifications and attached accessories.  
Above generator capacity will vary according to actual generator efficiency.

## Dimensions [ mm ]

Models	6AYL-WST	6AYL-WET
A	2970	3040
A'	1860	1860
B	1445	1445
C	1836	1836
D	2540	2600
E	1030	1030
F	619	619
G	1565	1565

Depending on the specifications or options that have been chosen,  
your model may differ slightly from the one in the photograph and outline.

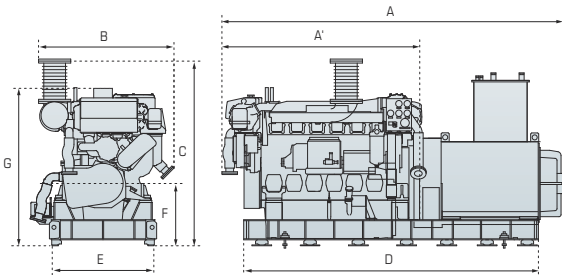

G : Minimum Height for Removing Piston ( Not included the dimension for bolt fitting to piston remove. )

• The various usage conditions, usage purposes, functions, terminology and expressions given in this catalogue are based on YANMAR CO., LTD. standards.

## YANMAR POWER TECHNOLOGY CO.,LTD.

### Head Office

YANMAR FLYING-Y BUILDING, 1-32,  
Chayamachi, Kita-ku, Osaka, 530-8311, Japan  
[yanmar.com](http://yanmar.com)

## YANMAR ENGINE (SHANGHAI) CO., LTD.

1101-1106, Gopher Center Building,  
No.757 Meng Zi Road, Shanghai, China 200023  
Tel : 21-2312-0688 Fax : 21-6880-8090 21-6880-8682  
[yanmar.com/cn/](http://yanmar.com/cn/)

## YANMAR ASIA (SINGAPORE) CORP. PTE. LTD.

4 Tuas Lane, Singapore 638613  
Tel : 65-6595-4200 Fax : 65-6862-5195  
[sg.yanmar.com](http://sg.yanmar.com)

## YANMAR EUROPE B.V.

Brugglein 11, 1332 BS Almere-de Vaart, The Netherlands  
Tel : 31-36-5493200 Fax : 31-36-5493209  
[www.yanmar.nl](http://www.yanmar.nl)

## YANMAR AMERICA CORP. HEAD OFFICE

101 International Parkway, Adairsville, GA 30103, U.S.A.  
Tel : 1-770-877-9894 Fax : 1-770-877-9009  
[us.yanmar.com](http://us.yanmar.com)

## YANMAR SOUTH AMERICA INDUSTRIA DE MAQUINAS LTDA.

Av. Presidente Vargas 1400, Indaiatuba, S.P. CEP: 13338-901, Brazil  
Tel : 55-19-3801-9224 Fax : 55-19-3875-3899 / 2241  
[www.yanmar.com.br/](http://www.yanmar.com.br/)